



PNEUMATIC

AIR

Air, it is a colorless and odorless gas mass composed of a mixture of many gases and dust particles in the world. Air is a mixture of about 78% nitrogen, 21% oxygen, 0.9% argon, 0.04% carbon dioxide, and very small amounts of other gases. There is an average of about 1% water vapour. It has an indefinite shape and volume. Pneumatics use air pressure to move things.

Introduction to Pneumatic System

Pneumatic technology deals with the study of behavior and applications of compressed air in our daily life in general and manufacturing automation in particular. Pneumatic systems use air as the medium which is abundantly available and can be exhausted into the atmosphere after completion of the assigned task.

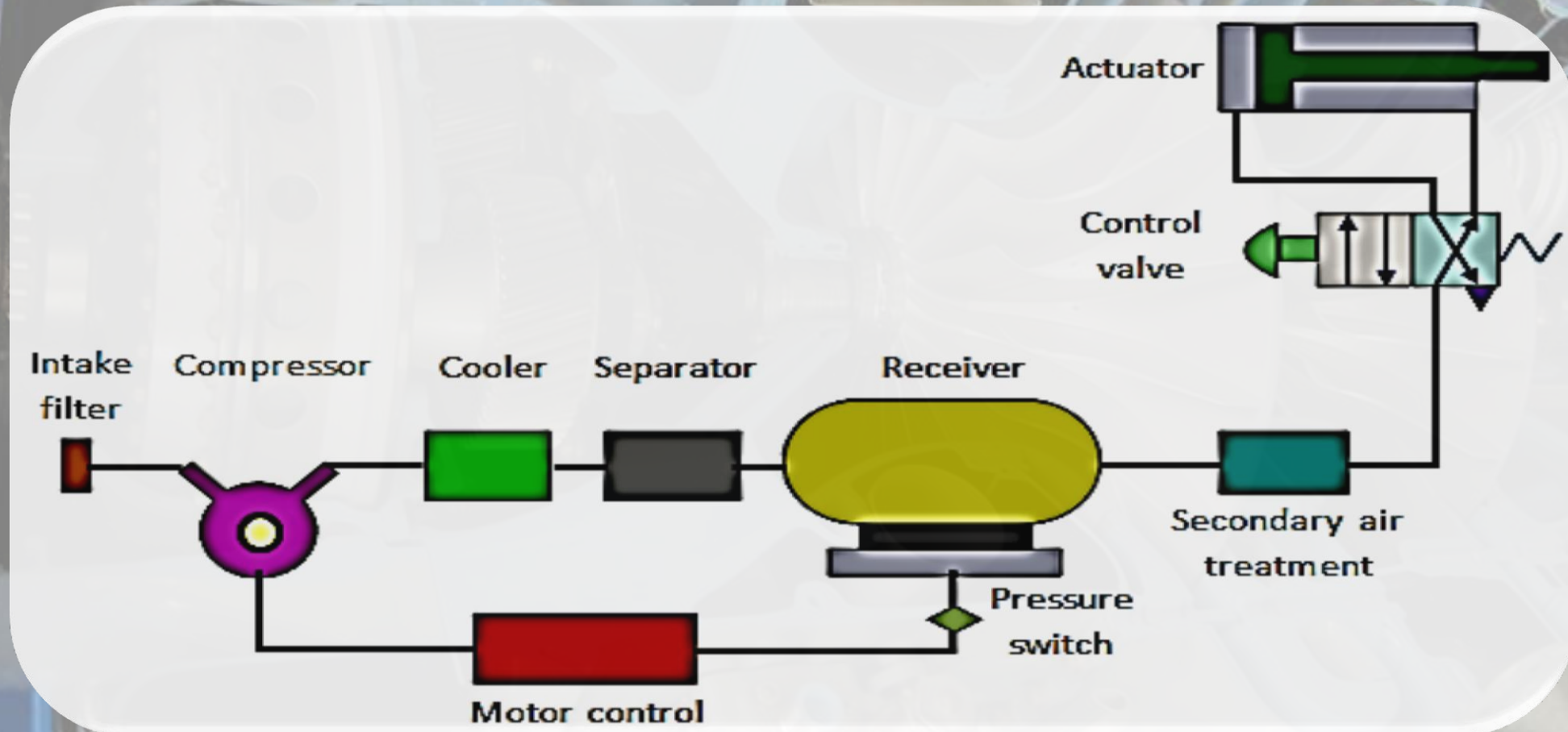

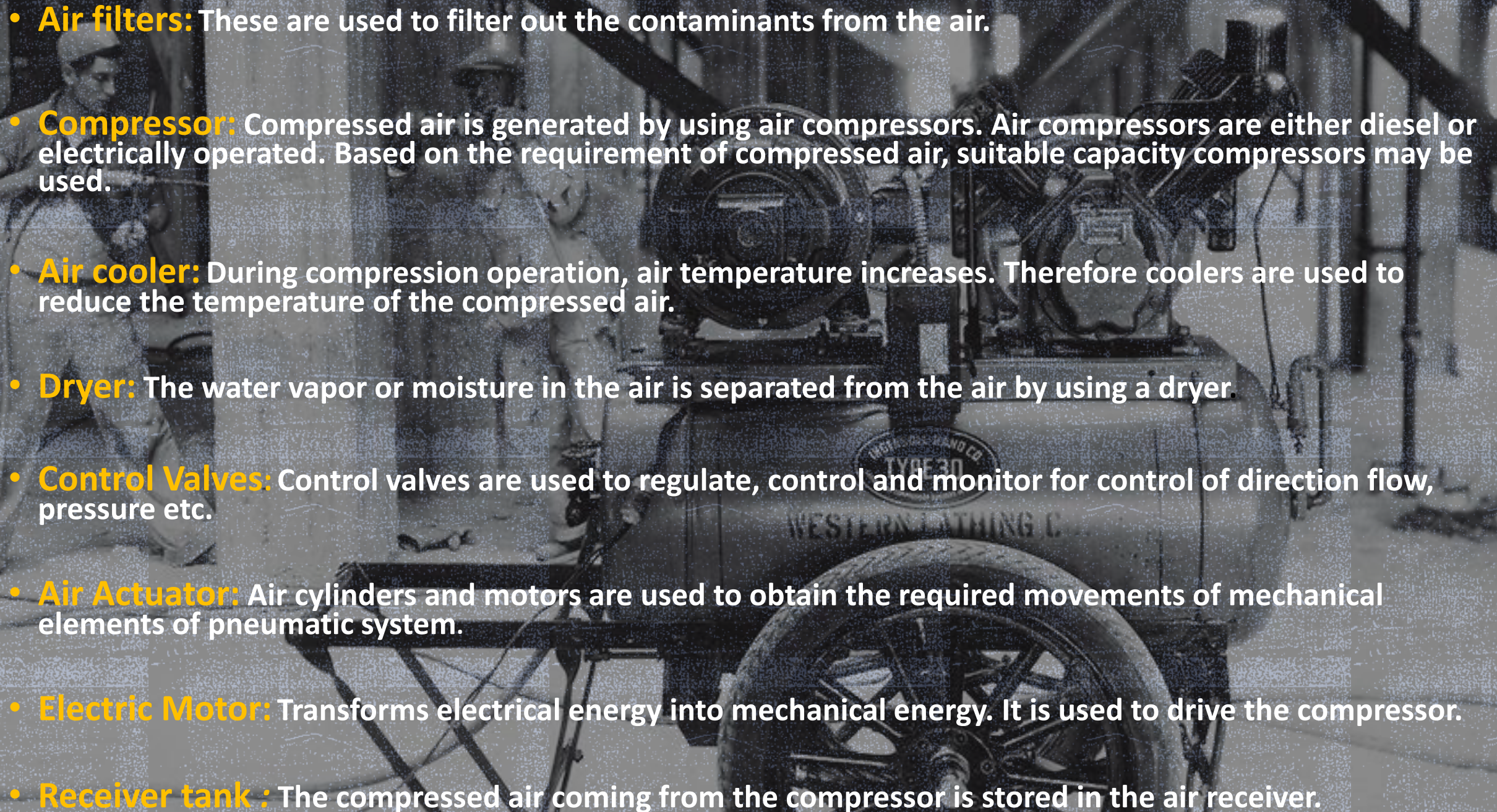
- 
- A vintage Western Machine Co. Type 30 air compressor is the central focus, mounted on a wooden cart with large spoked wheels. The compressor is a complex mechanical device with various pipes, valves, and a large flywheel. A man in a light-colored shirt and dark trousers stands in the background, looking towards the camera. The scene is set in what appears to be a workshop or a factory floor.
- **Air filters:** These are used to filter out the contaminants from the air.
 - **Compressor:** Compressed air is generated by using air compressors. Air compressors are either diesel or electrically operated. Based on the requirement of compressed air, suitable capacity compressors may be used.
 - **Air cooler:** During compression operation, air temperature increases. Therefore coolers are used to reduce the temperature of the compressed air.
 - **Dryer:** The water vapor or moisture in the air is separated from the air by using a dryer.
 - **Control Valves:** Control valves are used to regulate, control and monitor for control of direction flow, pressure etc.
 - **Air Actuator:** Air cylinders and motors are used to obtain the required movements of mechanical elements of pneumatic system.
 - **Electric Motor:** Transforms electrical energy into mechanical energy. It is used to drive the compressor.
 - **Receiver tank :** The compressed air coming from the compressor is stored in the air receiver.

Air Compressor

An air compressor is a device that converts power (using an electric motor, diesel or gasoline engine, etc.) into potential energy stored in pressurized air (i.e., compressed air). By one of several methods, an air compressor forces more and more air into a storage tank, increasing the pressure. When tank pressure reaches its engineered upper limit the air compressor shuts off. The compressed air, then, is held in the tank until called into use. The energy contained in the compressed air can be used for a variety of applications, utilizing the kinetic energy of the air as it is released and the tank depressurizes. When tank pressure reaches its lower limit, the air compressor turns on again and re-pressurizes the tank. An air compressor must be differentiated from a pump because it works for any gas/air, while pumps work on a liquid.

The compressor can be classified into two main types

- Positive displacement compressors and
- Dynamic displacement compressor

1) Positive Displacement

Positive-displacement compressors work by forcing air in a chamber whose volume is decreased to compress the air. Once the maximum pressure is reached, a port or valve opens and air is discharged into the outlet system from the compression chamber. Common types of positive displacement compressors are

- 1.1 Piston compressors**
- 1.2 Double acting compressor**
- 1.3 Multistage compressor**
- 1.4 Combined two stage compressors**
- 1.5 Diaphragm compressor**
- 1.6 Screw compressor**
- 1.7 Rotary vane compressors**
- 1.8 Liquid ring compressor**
- 1.9 Lobe compressor**

1.1 Piston Compressors

Piston compressors are commonly used in pneumatic systems. The simplest form is single cylinder compressor (Fig.). It produces one pulse of air per piston stroke. As the piston moves down during the inlet stroke the inlet valve opens and air is drawn into the cylinder. As the piston moves up the inlet valve closes and the exhaust valve opens which allows the air to be expelled. The valves are spring loaded. The single cylinder compressor gives significant amount of pressure pulses at the outlet port. The pressure developed is about 3-40 bar.

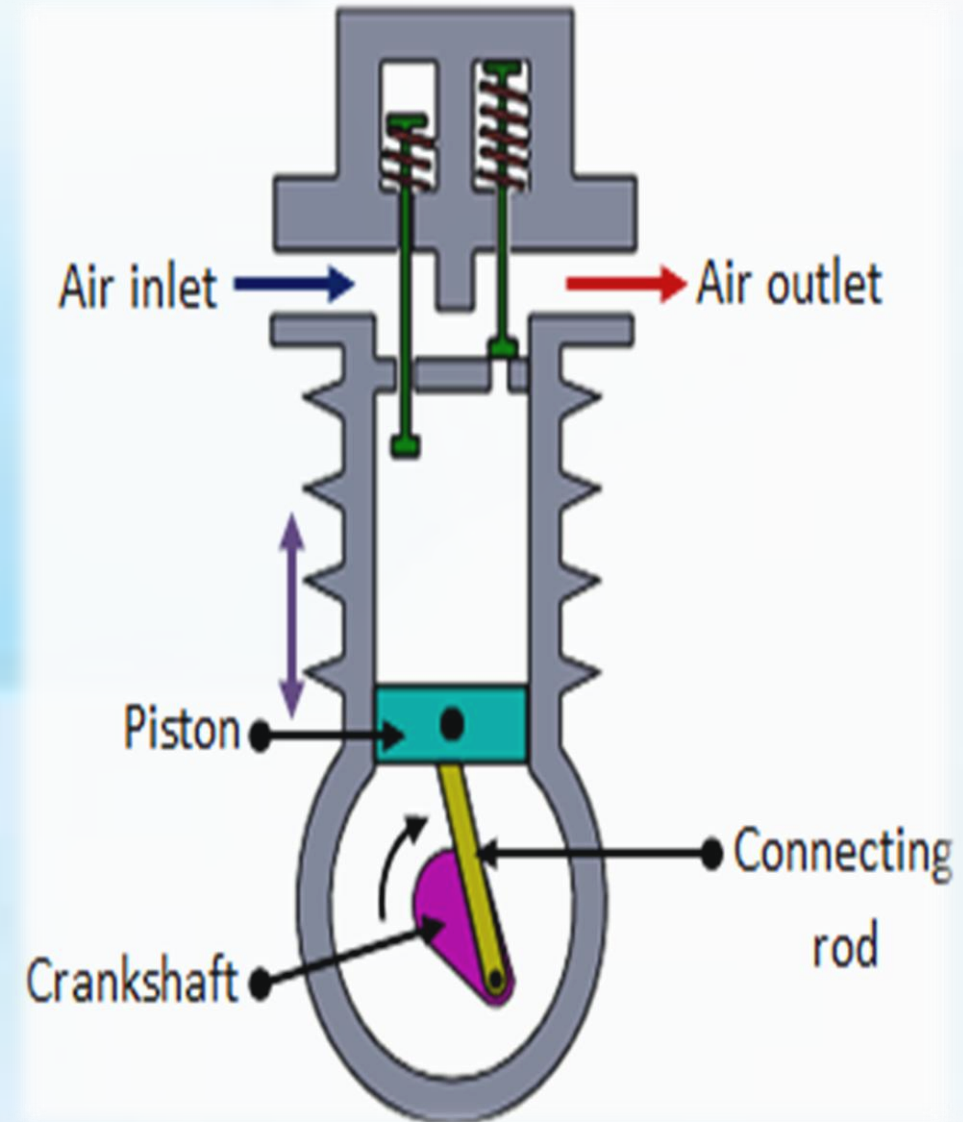

1.2 Double Acting Compressor

The pulsation of air can be reduced by using double acting compressor as shown in Figure. It has two sets of valves and a crosshead. As the piston moves, the air is compressed on one side whilst on the other side of the piston, the air is sucked in. Due to the reciprocating action of the piston, the air is compressed and delivered twice in one piston stroke. Pressure higher than 30bar can be produced.

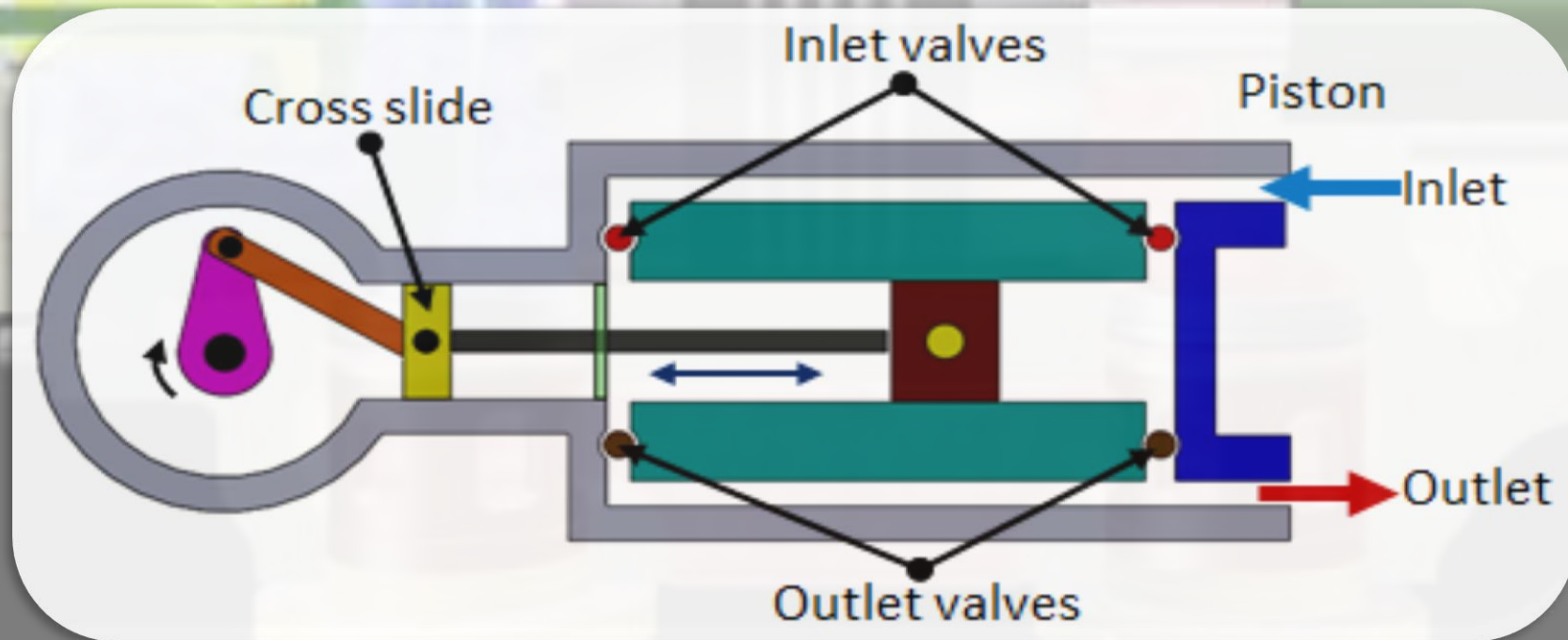

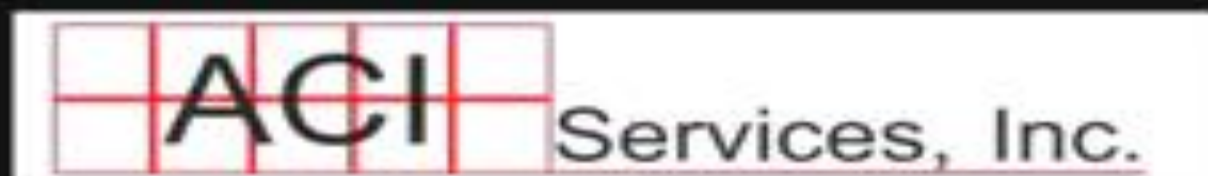

DOUBLE ACTING COMPRESSOR CYLINDER

1.3 Multistage Compressor

As the pressure of the air increases, its temperature rises. It is essential to reduce the air temperature to avoid damage of compressor and other mechanical elements. The multistage compressor with intercooler in-between is shown in Figure. It is used to reduce the temperature of compressed air during the compression stages. The intercooling reduces the volume of air which used to increase due to heat.

The compressed air from the first stage enters the intercooler where it is cooled. This air is given as input to the second stage where it is compressed again. The multistage compressor can develop a pressure of around 50bar.

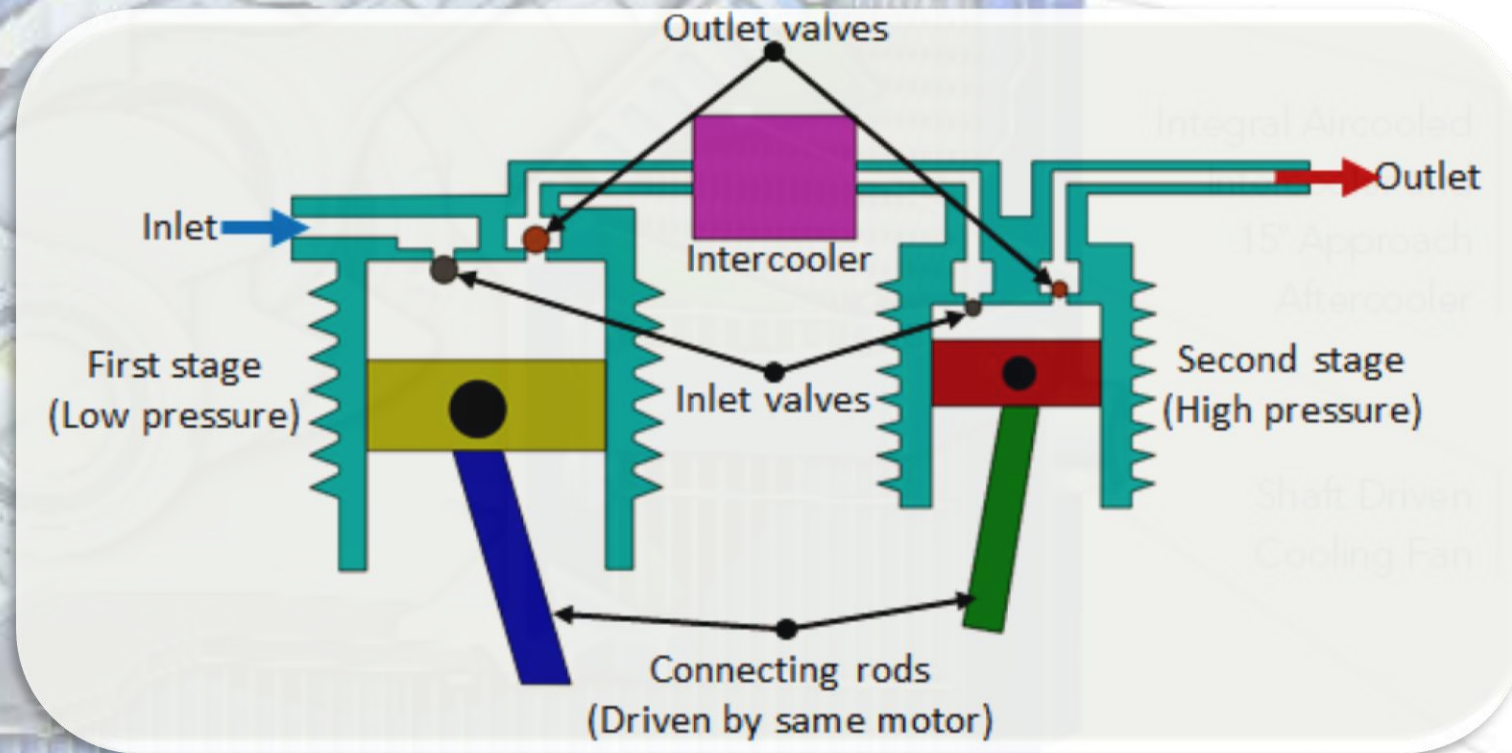

1.4 Combined Two Stage Compressors

In this type, two-stage compression is carried out by using the same piston (Fig.). Initially when the piston moves down, air is sucked in through the inlet valve. During the compression process, the air moves out of the exhaust valve into the intercooler. As the piston moves further the stepped head provided on the piston moves into the cavity thus causing the compression of air. Then, this is let out by the exhaust port.

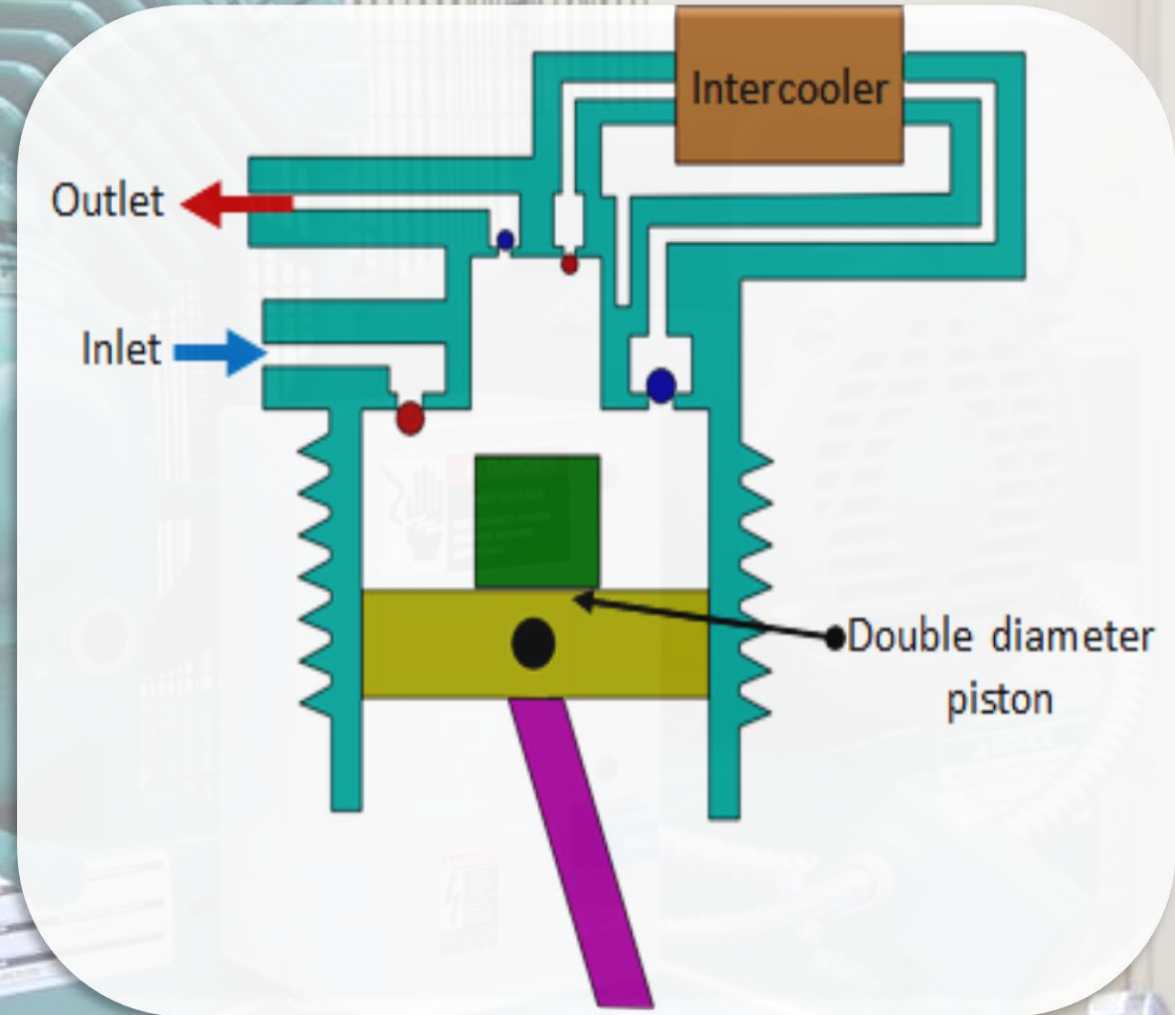

1.5 Diaphragm Compressor

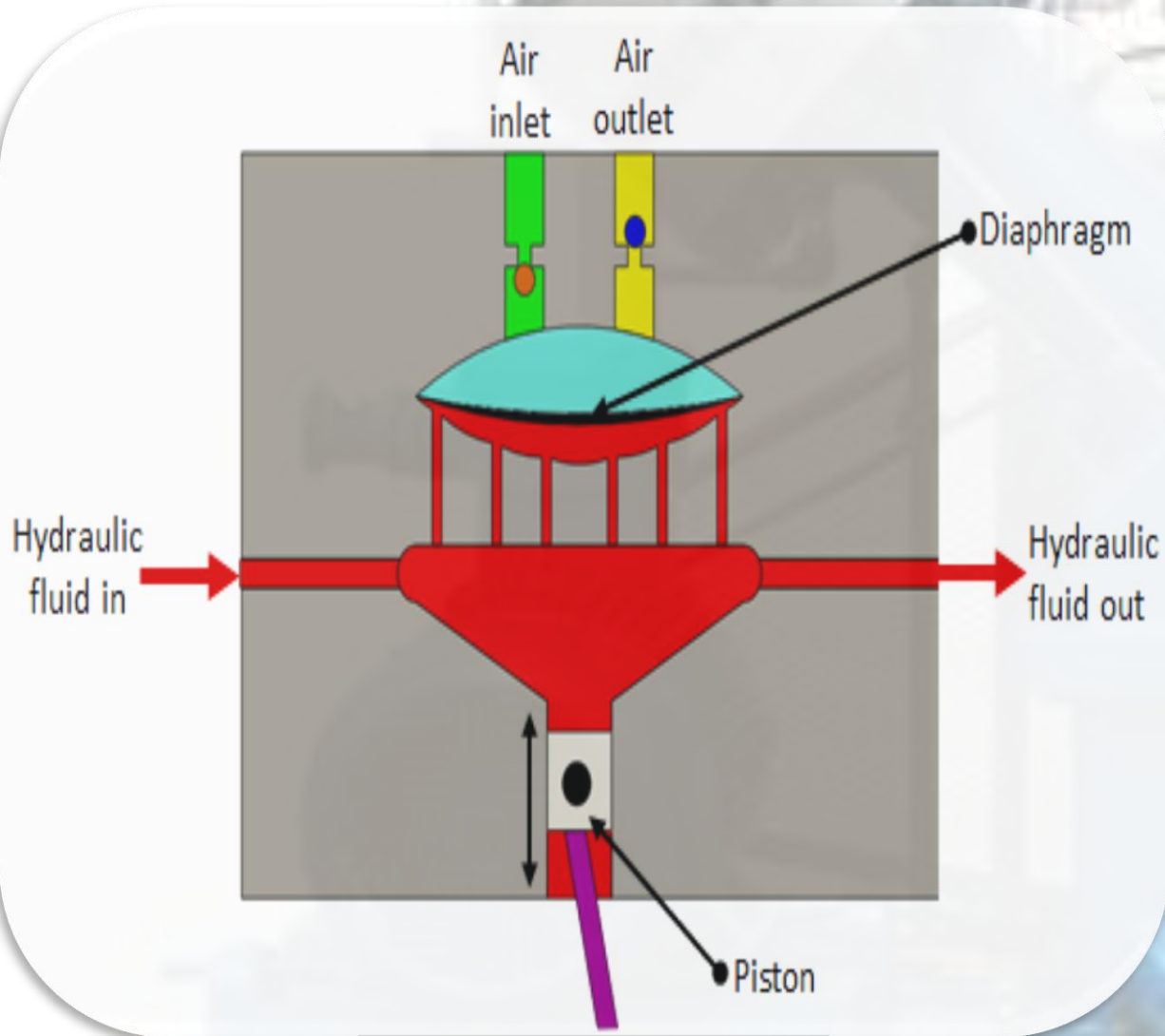

These are small capacity compressors. In piston compressors the lubricating oil from the pistons walls may contaminate the compressed air. The contamination is undesirable in food, pharmaceutical and chemical industries. For such applications diaphragm type compressor can be used. Figure shows the construction of Diaphragm compressor. The piston reciprocates by a motor driven crankshaft. As the piston moves down it pulls the hydraulic fluid down causing the diaphragm to move along and the air is sucked in. When the piston moves up the fluid pushes the diaphragm up causing the ejection of air from the outlet port. Since the flexible diaphragm is placed in between the piston and the air no contamination takes place.

1.6 Screw Compressor

Piston compressors are used when high pressures and relatively low volume of air is needed. The system is complex as it has many moving parts. For medium flow and pressure applications, screw compressor can be used. It is simple in construction with less number of moving parts. The air delivered is steady with no pressure pulsation. It has two meshing screws.

The air from the inlet is trapped between the meshing screws and is compressed. The contact between the two meshing surface is minimum, hence no cooling is required. These systems are quite in operation compared to piston type. The screws are synchronized by using external timing gears.

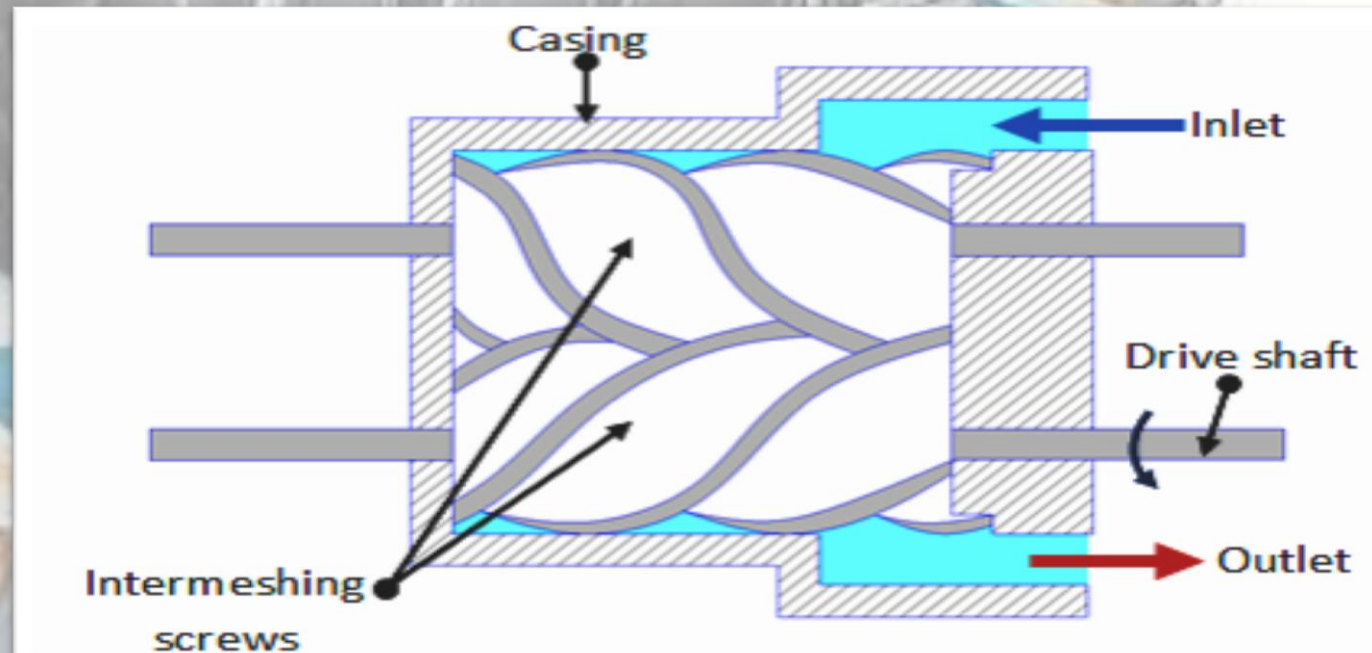

1.7 Rotary Vane Compressors

The principle of operation of vane compressor is similar to the hydraulic vane pump. Figure shows the working principle of Rotary vane compressor. The unbalanced vane compressor consists of spring loaded vanes seating in the slots of the rotor. The pumping action occurs due to movement of the vanes along a cam ring. The rotor is eccentric to the cam ring.

As the rotor rotates, the vanes follow the inner surface of the cam ring. The space between the vanes decreases near the outlet due to the eccentricity. This causes compression of the air. These compressors are free from pulsation. If the eccentricity is zero no flow takes place.

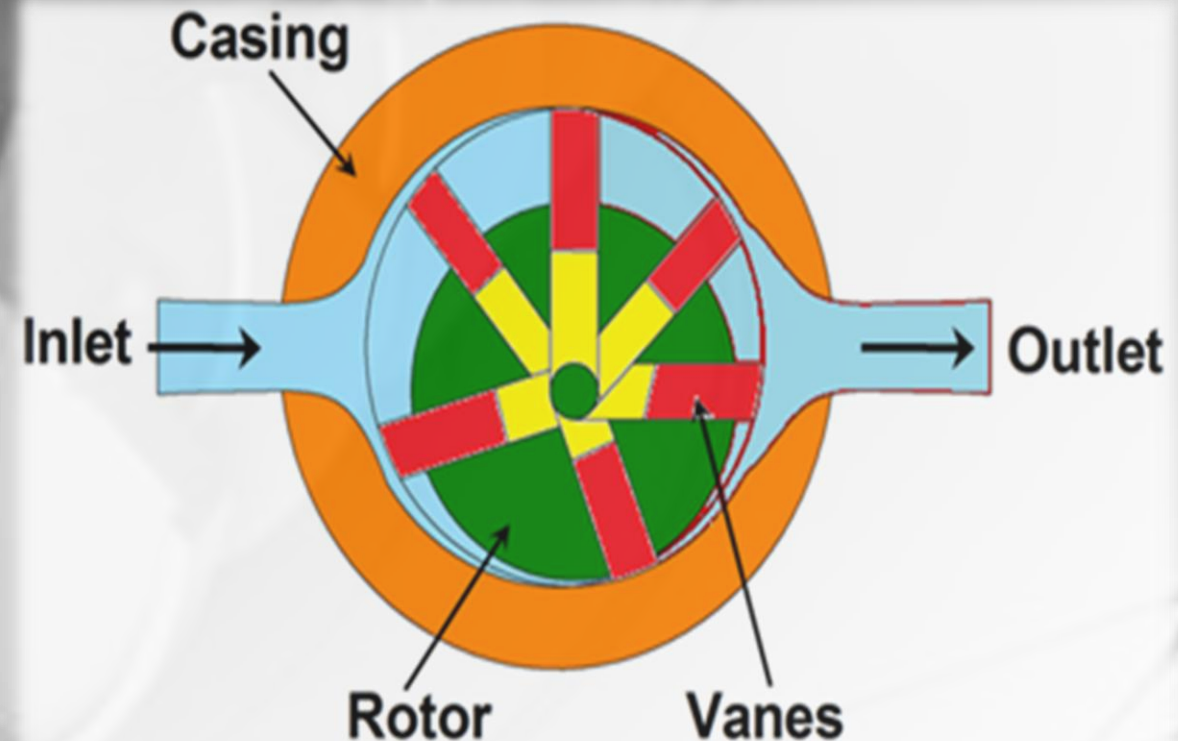

1.8 Liquid Ring Compressor

Liquid ring vane compressor is a variation of vane compressors. Figure shows the construction of Liquid ring compressor. The casing is filled with liquid up to rotor center. The air enters the compressor through the distributor fixed to the compressor. During the impeller rotation, the liquid will be centrifuged along the inner ring of the casing to form the liquid ring. There are two suction and discharge ports provided in the distributor. During the first quarter of cycle, the air is sucked in both suction chambers of the casing and during the second quarter of the cycle, the air is compressed and pushed out through the two discharge ports.

During the third and fourth quarters of the cycle, the process is repeated. This type of compressor has no leakage and has minimal friction. For smooth operation, the rotation speed should be about 3000rpm. The delivery pressure is low (about 5 bar).

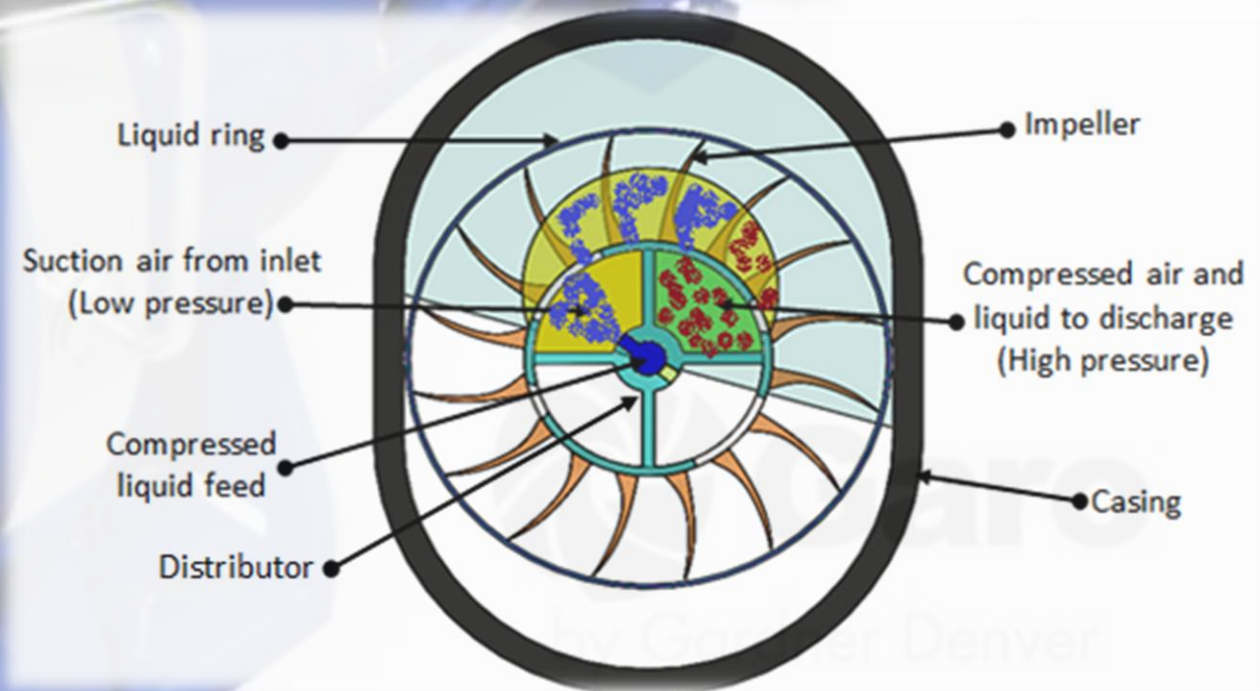

1.9 Lobe Compressor

The lobe compressor is used when high delivery volume but low pressure is needed. It consists of two lobes with one being driven and the other driving. Figure shows the construction and working of Lobe compressor. It is similar to the Lobe pump used in hydraulic systems. The operating pressure is limited by leakage between rotors and housing. As the wear increases during the operation, the efficiency falls rapidly.

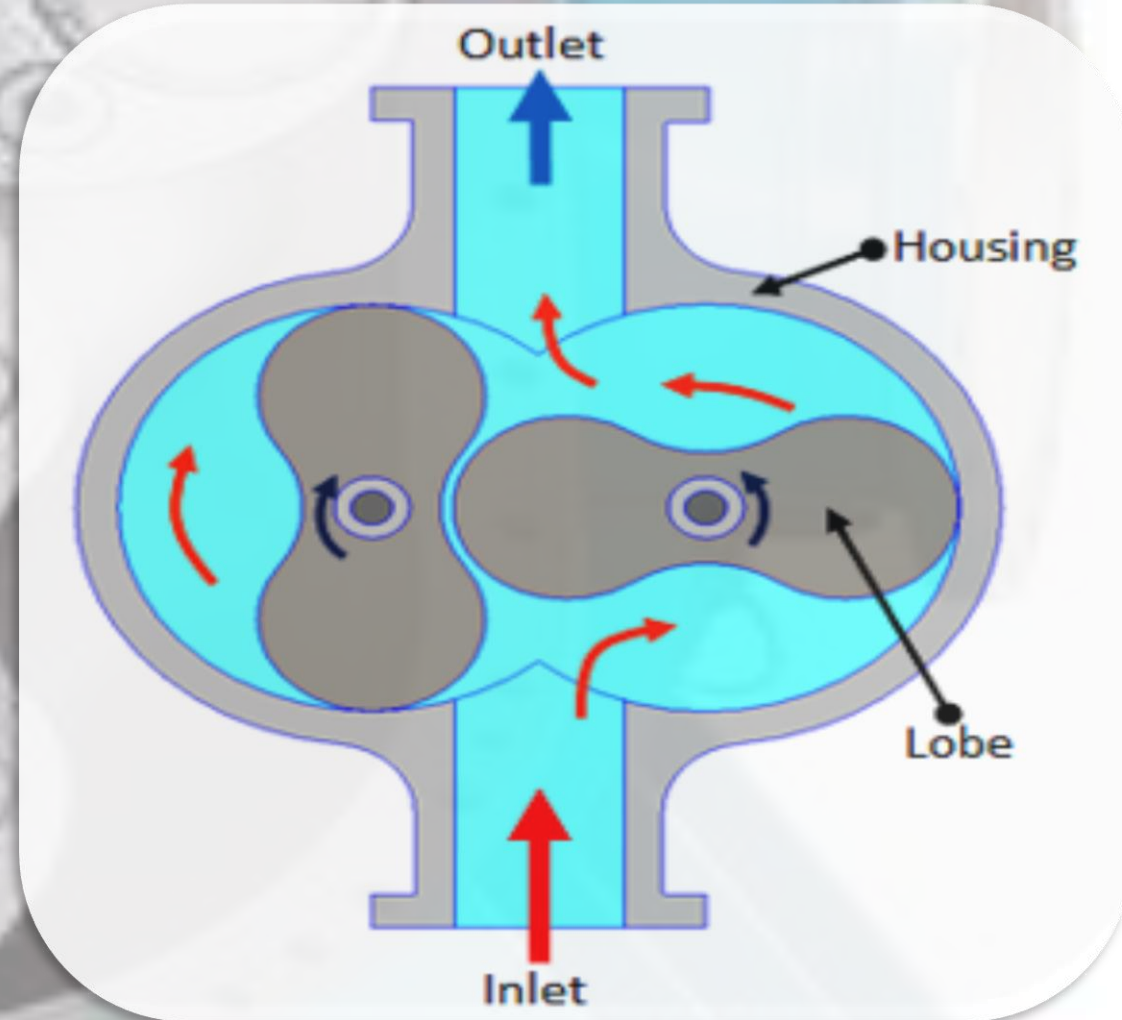

2) Dynamic Compressors

Dynamic displacement air compressors include centrifugal compressors and axial compressors. In these types, a rotating component imparts its kinetic energy to the air which is eventually converted into pressure energy. These use centrifugal force generated by a spinning impeller to accelerate and then decelerate captured air, which pressurizes it.

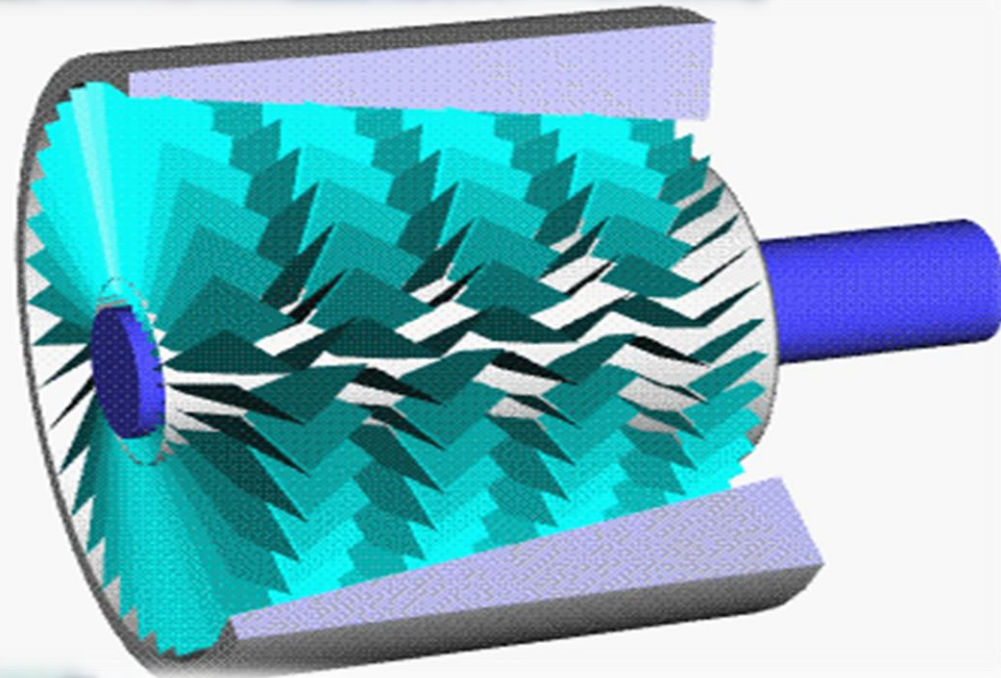

2.1 Centrifugal Compressors

When very large volume of compressed air is required in applications such as ventilators, combustion system and pneumatic powder blower conveyors, the dynamic compressor can be used. The pressure needed is very low in such applications. Figure shows a typical Centrifugal type blower. The impeller rotates at a high speed. Large volume of low pressure air can be provided by blowers.

The blowers draw the air in and the impeller flings it out due to centrifugal force. Positive displacement compressors need oil to lubricate the moving parts, whereas the dynamic compressors have no such need. The efficiency of these compressors is better than that of reciprocating types.

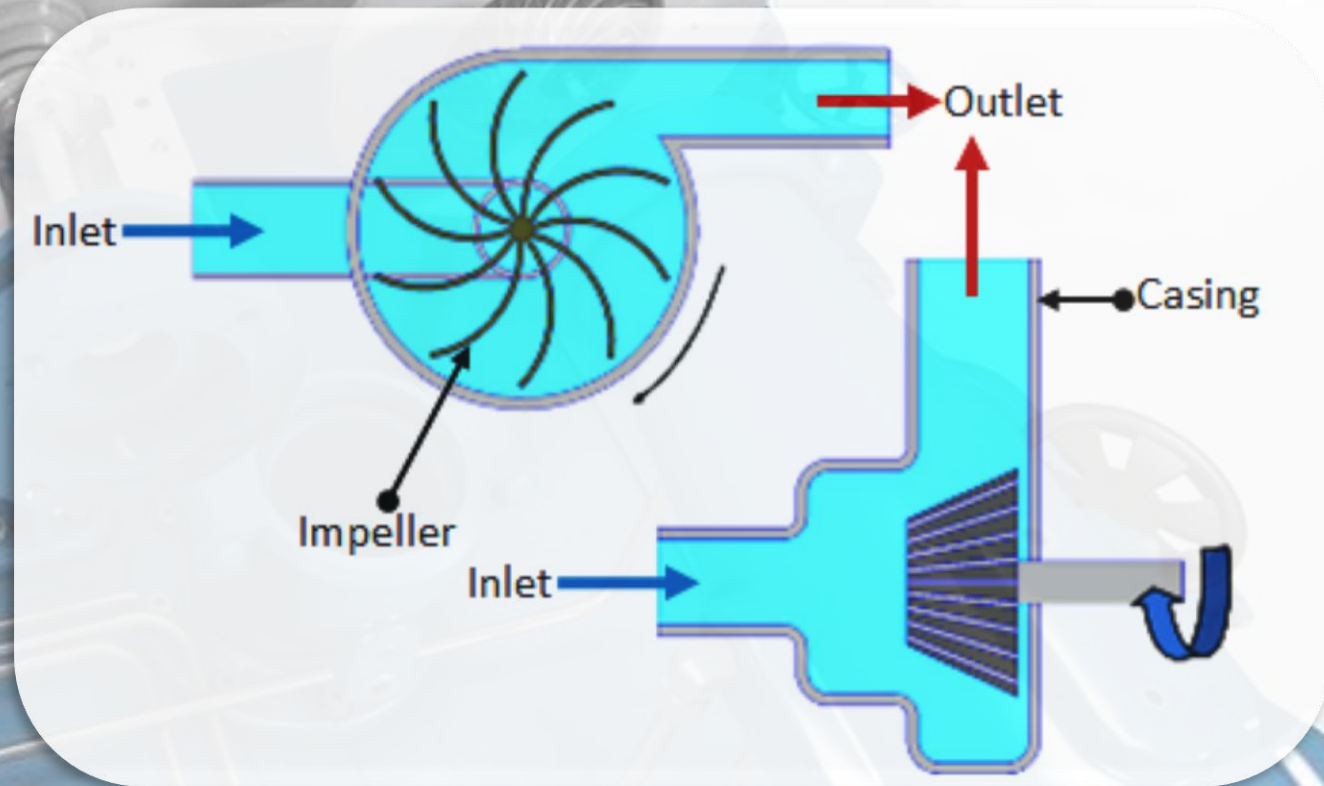



MAN Diesel & Turbo

Air Treatment Stages

For satisfactory operation of the pneumatic system the compressed air needs to be cleaned and dried. Atmospheric air is contaminated with dust, smoke and is humid. These particles can cause wear of the system components and presence of moisture may cause corrosion. Hence it is essential to treat the air to get rid of these impurities. The air treatment can be divided into three stages as shown in Figure.

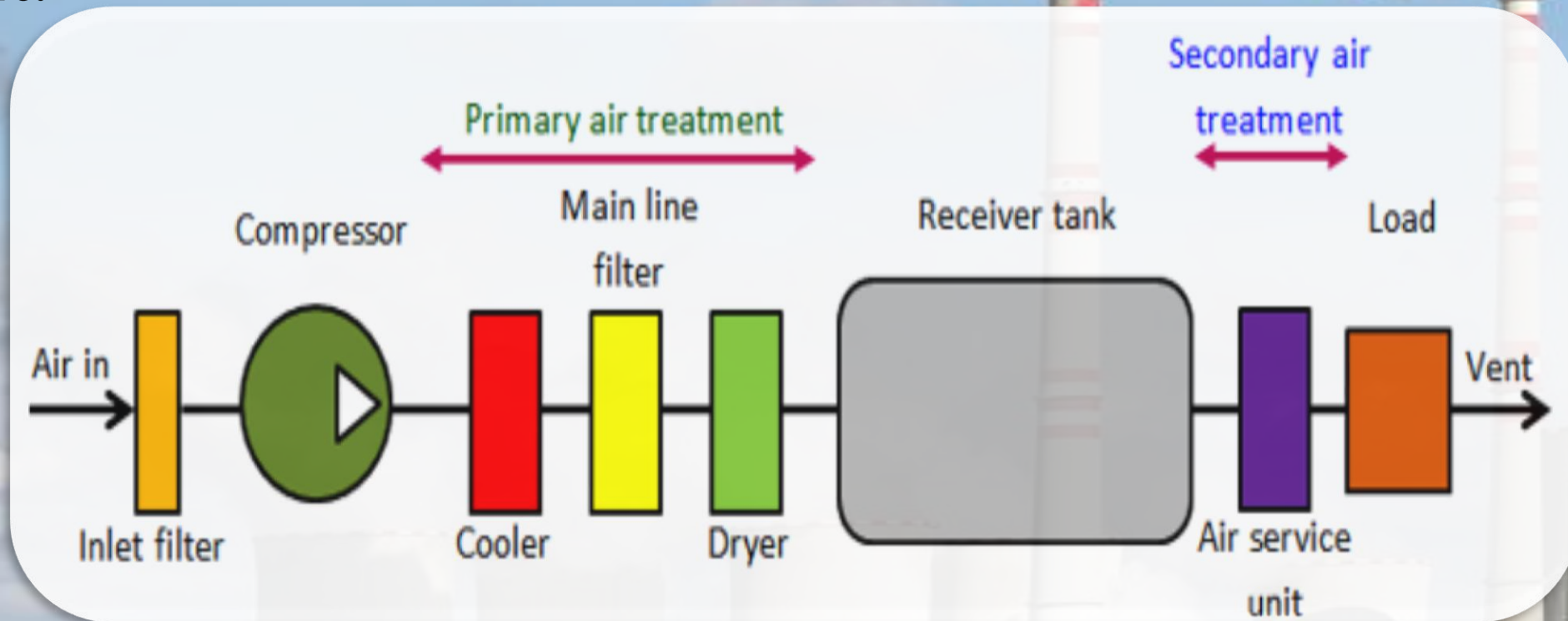

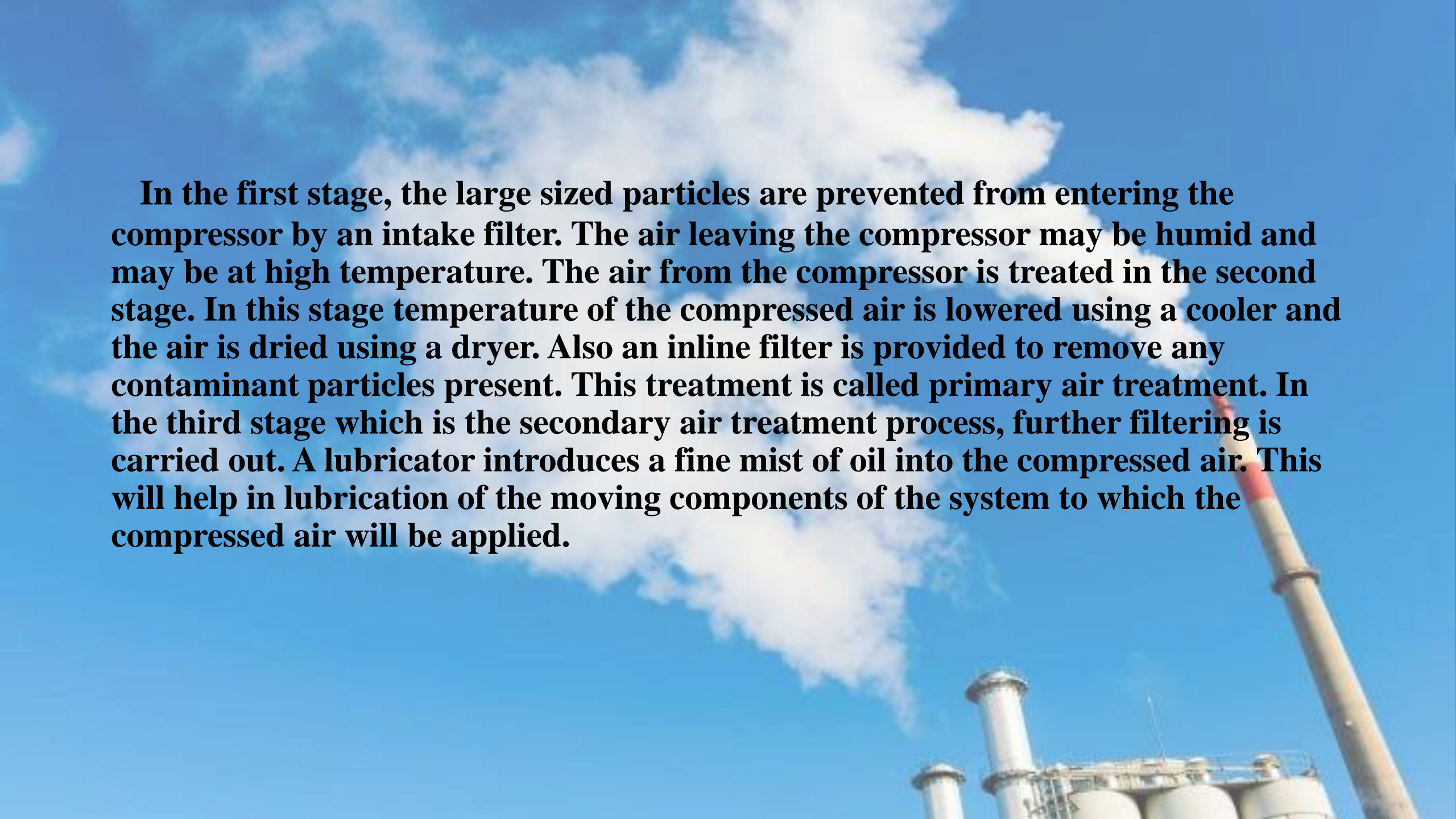

In the first stage, the large sized particles are prevented from entering the compressor by an intake filter. The air leaving the compressor may be humid and may be at high temperature. The air from the compressor is treated in the second stage. In this stage temperature of the compressed air is lowered using a cooler and the air is dried using a dryer. Also an inline filter is provided to remove any contaminant particles present. This treatment is called primary air treatment. In the third stage which is the secondary air treatment process, further filtering is carried out. A lubricator introduces a fine mist of oil into the compressed air. This will help in lubrication of the moving components of the system to which the compressed air will be applied.

Filters

To prevent any damage to the compressor, the contaminants present in the air need to be filtered out. This is done by using inlet filters. These can be dry or wet filters. Dry filters use disposable cartridges. In the wet filter, the incoming air is passed through an oil bath and then through a fine wire mesh filter. Dirt particles cling to the oil drops during bubbling and are removed by wire mesh as they pass through it. In the dry filter the cartridges are replaced during servicing. The wet filters are cleaned using detergent solution.

dust
bacteria
fungus
pollen
mold
odor
VOCs

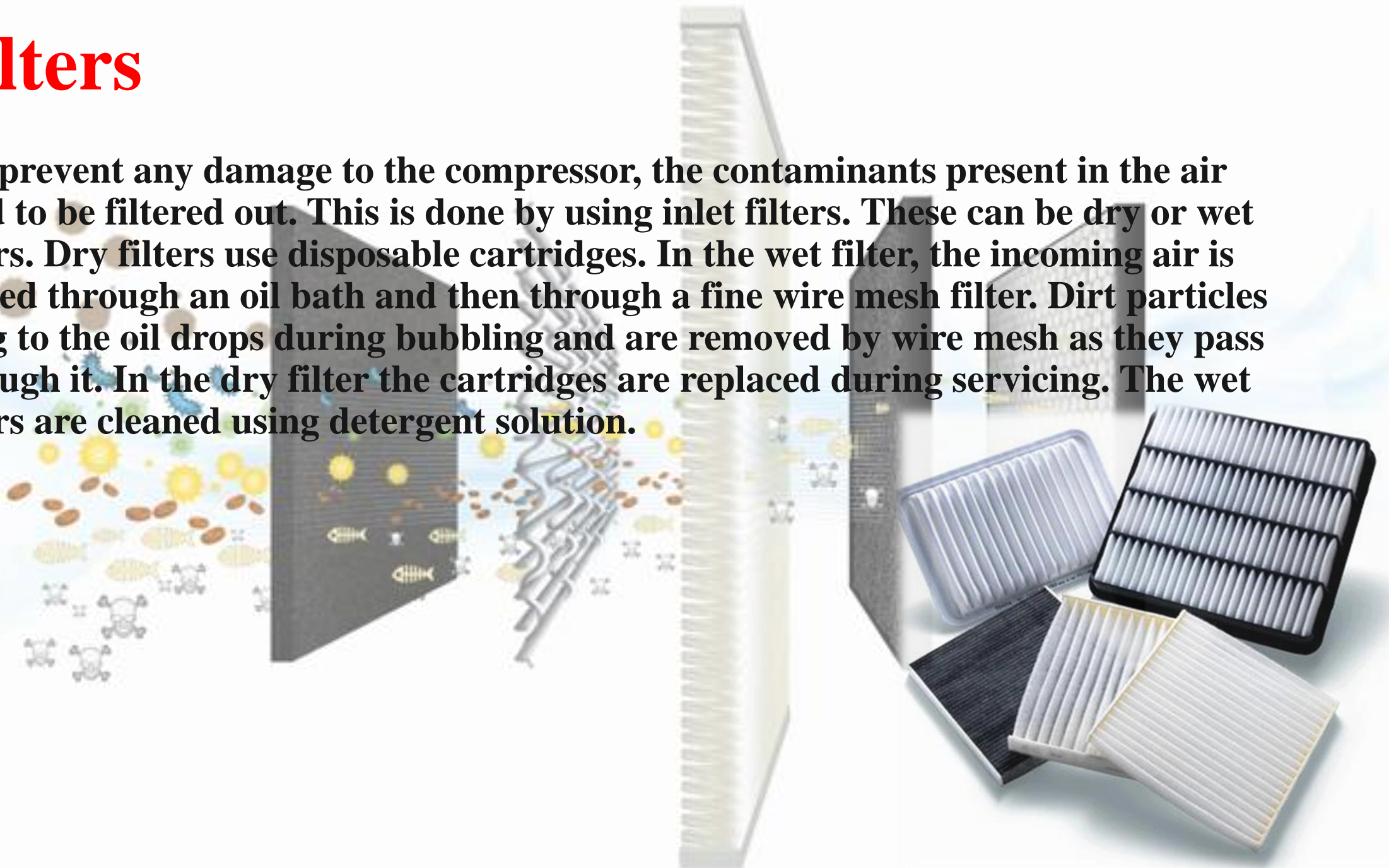

Cooler

As the air is compressed, the temperature of the air increases. Therefore the air needs to be cooled. This is done by using a cooler. It is a type of heat exchanger. There are two types of coolers commonly employed viz. air cooled and water cooled. In the air cooled type, ambient air is used to cool the high temperature compressed air, whereas in the water cooled type, water is used as cooling medium. These are counter flow type coolers where the cooling medium flows in the direction opposite to the compressed air. During cooling, the water vapor present will condense which can be drained away later.

Main Line Filters

These filters are used to remove the water vapors or solid contaminants present in the pneumatic systems main lines. These filters are discussed in detail as follows.

Air Filter and Water Trap

Air filter and water trap is used to

- prevent any solid contaminants from entering in the system.**
- condense and remove water vapor that is present in the compressed air.**

Air Filter and Water Trap

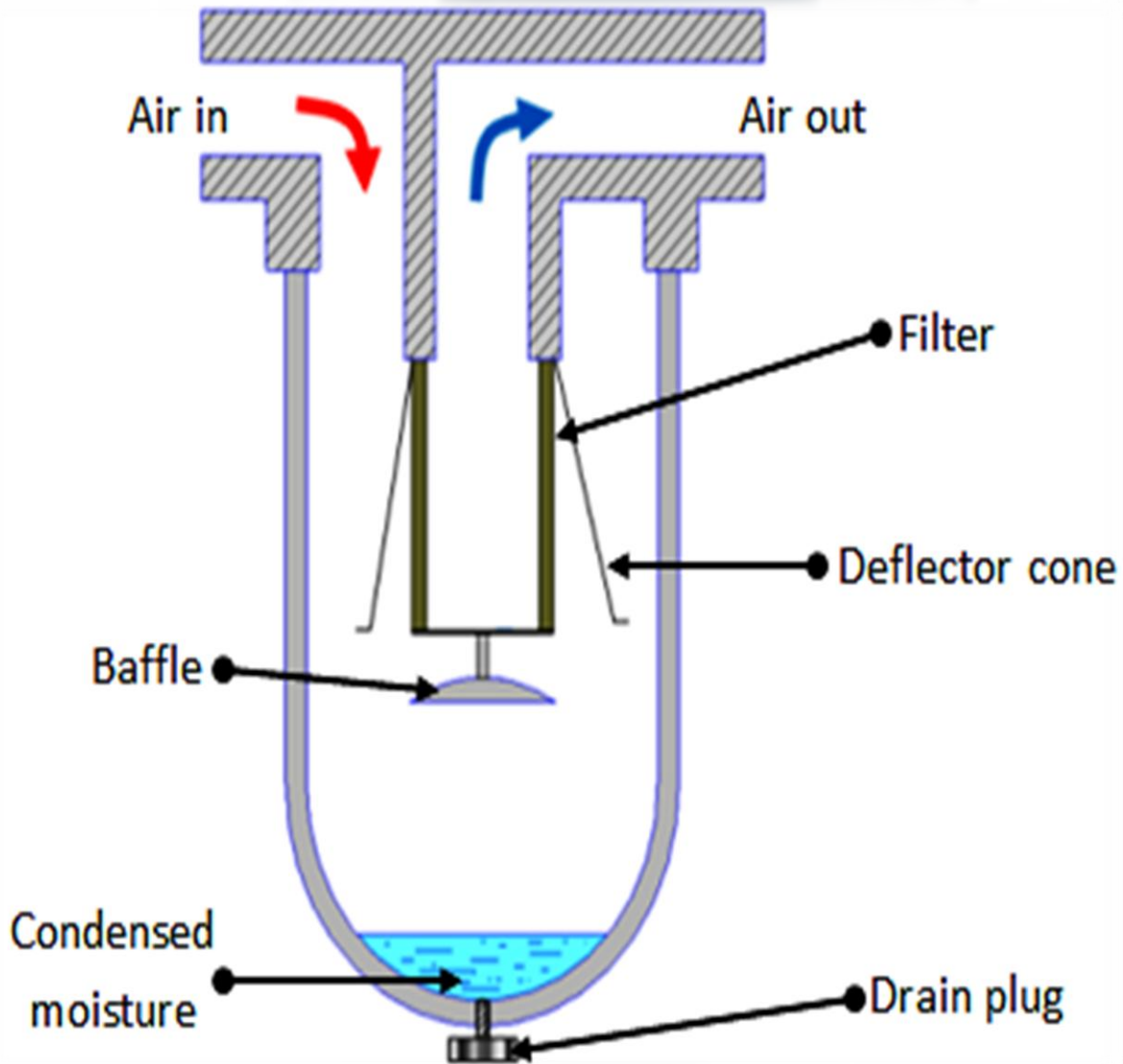

The filter cartridge is made of sintered brass. The schematic of the filter is shown in Fig. The thickness of sintered cartridge provides random zigzag passage for the air to flow-in which helps in arresting the solid particles. The air entering the filter swirls around due to the deflector cone. The centrifugal action causes the large contaminants and water vapor to be flung out, which hit the glass bowl and get collected at the bottom. A baffle plate is provided to prevent the turbulent air from splashing the water into the filter cartridge. At the bottom of the filter bowl there is a drain plug which can be opened manually to drain off the settled water and solid particles.

Refrigerated Dryers

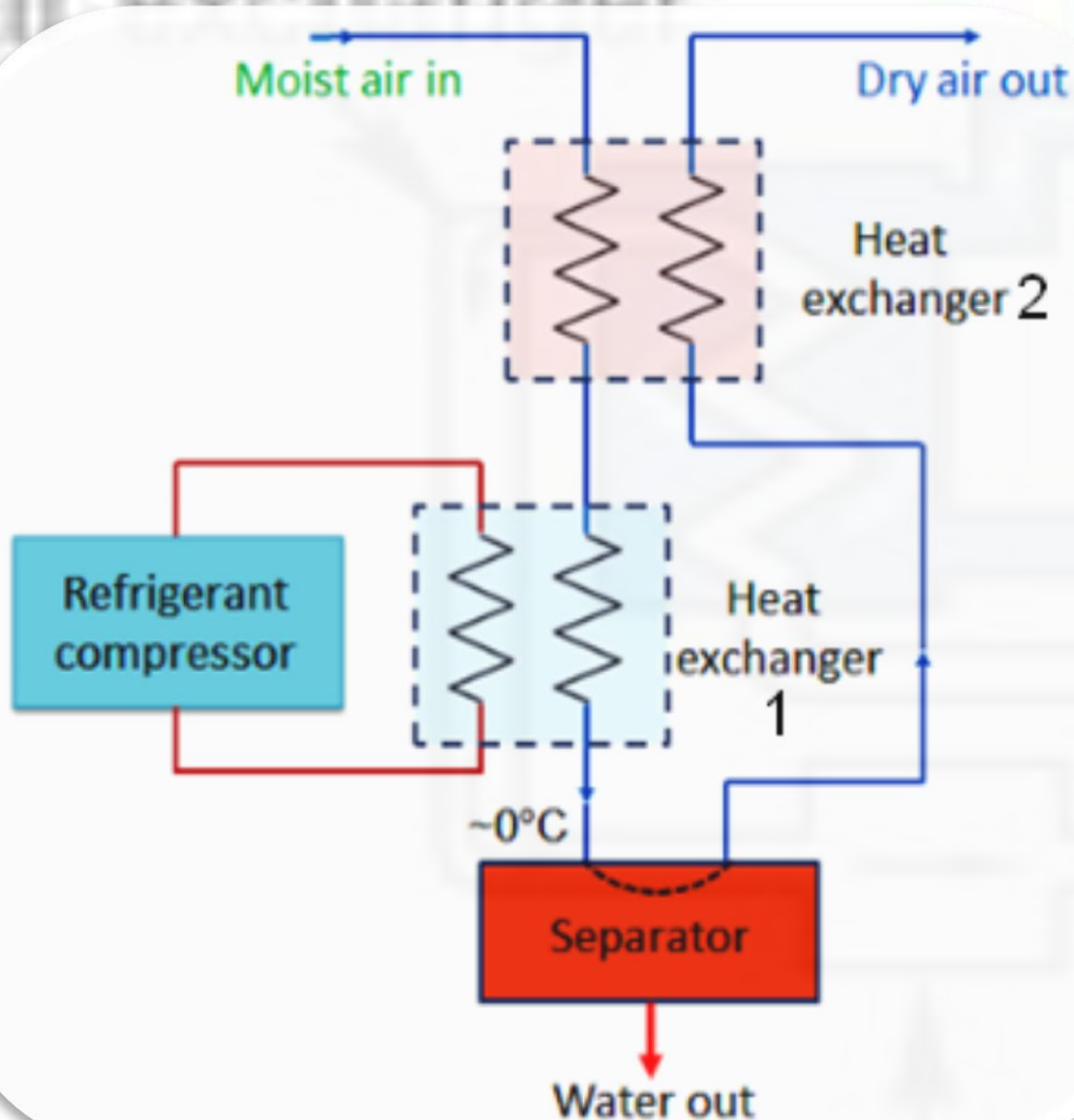

It consists of two heat exchangers, refrigerant compressor and a separator. The system circuitry is shown in Figure. The dryer chills the air just above 0°C which condenses the water vapor. The condensate is collected by the separator. However such low temperature air may not be needed at the application. Therefore this chilled air is used to cool the high temperature air coming out from the compressor at heat exchanger 2. The moderate temperature dry air coming out from the heat exchanger 2 is then used for actual application; whilst the reduced temperature air from compressor will further be cooled at heat exchanger 1. Thus, the efficiency of the system is increased by employing a second heat exchanger.

Chemical Dryers

When absolute dry air is needed chemical dryers are used. These dryers are of two types namely adsorption dryer and absorption dryer.

Absorption Dryers

These are also called as deliquescent dryers. Figure shows a schematic of the same. It uses chemical agents like phosphoric pentoxide or calcium chloride as drying agents. The moisture in the compressed air chemically reacts with the drying agent. The agent dissolves to form a liquid compound which collects at the bottom of the dryer where it can be drained out. The deliquescent agent has to be replenished regularly as it gets consumed during the drying process.

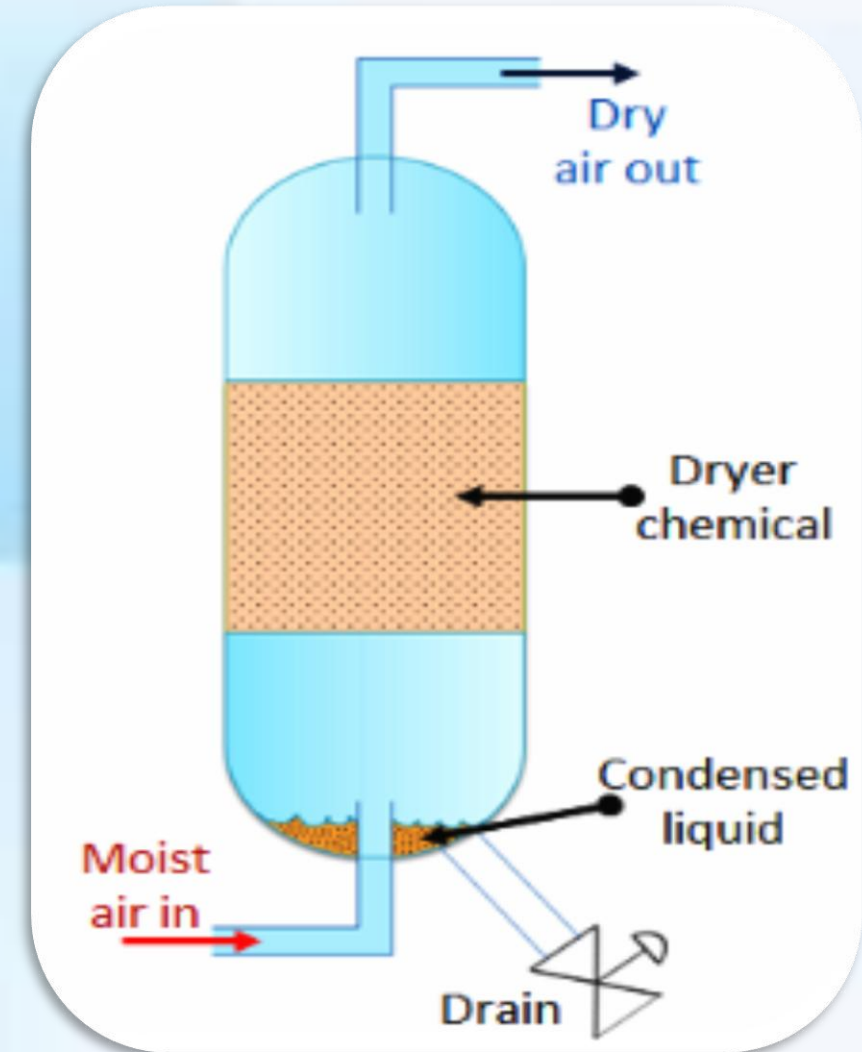

Adsorption Dryers

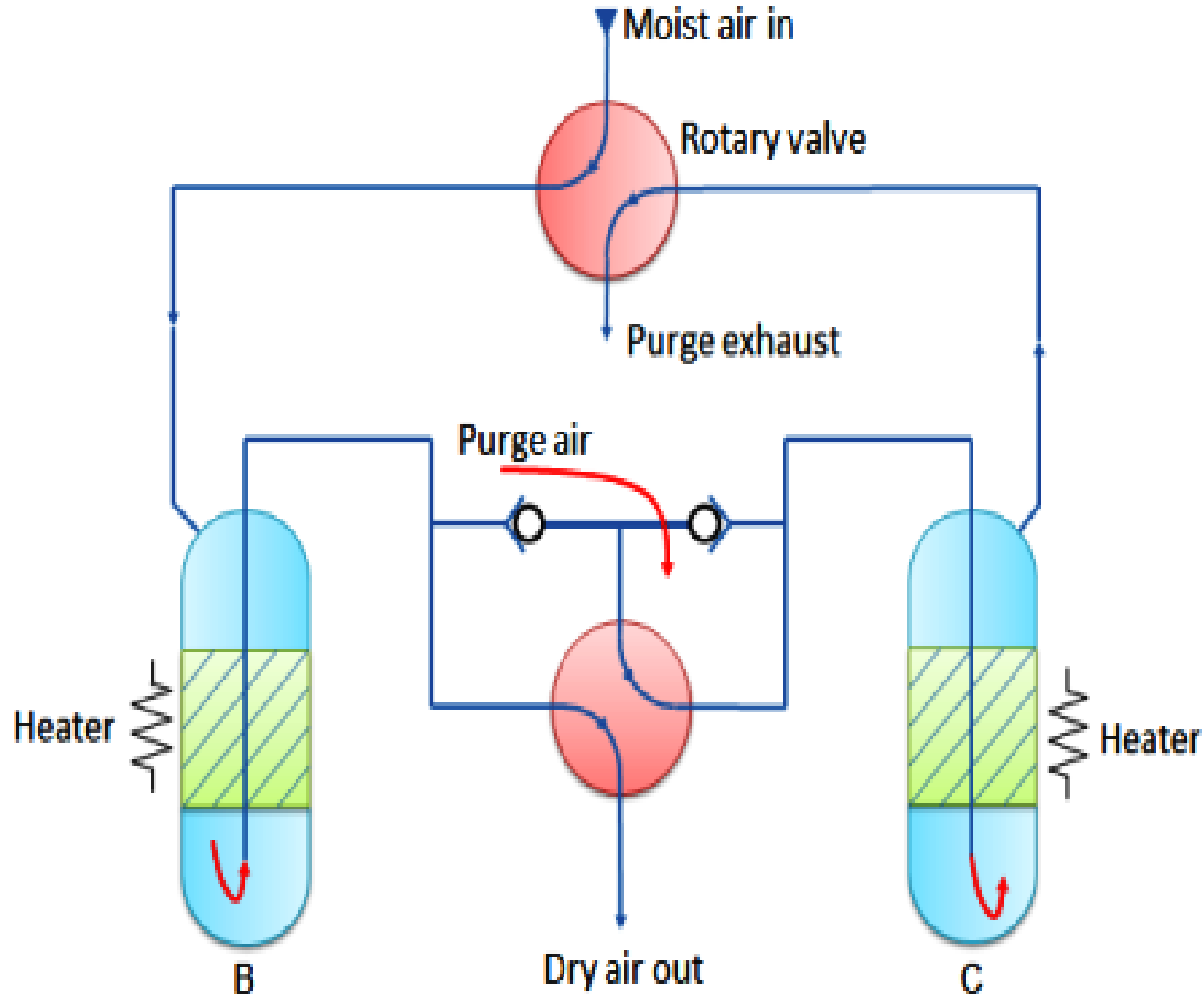

In Adsorption dryers, the moisture collects on the sharp edges of the granular material. The adsorbing materials can be silicon dioxide (silica gel) or other materials which exist in hydrated and dehydrated state (copper sulphate, activated alumina). Moisture from the adsorbing material can be released by heating in the column as shown in Fig. At a given time, one column will dry the air while the other column will regenerate the adsorption material by heating and passing low purge air. The column B dries the air and column C regenerates. The rotary valves are opened using time clock at regular interval to reverse the process. These driers are also called regenerative dryers.



Lubricators

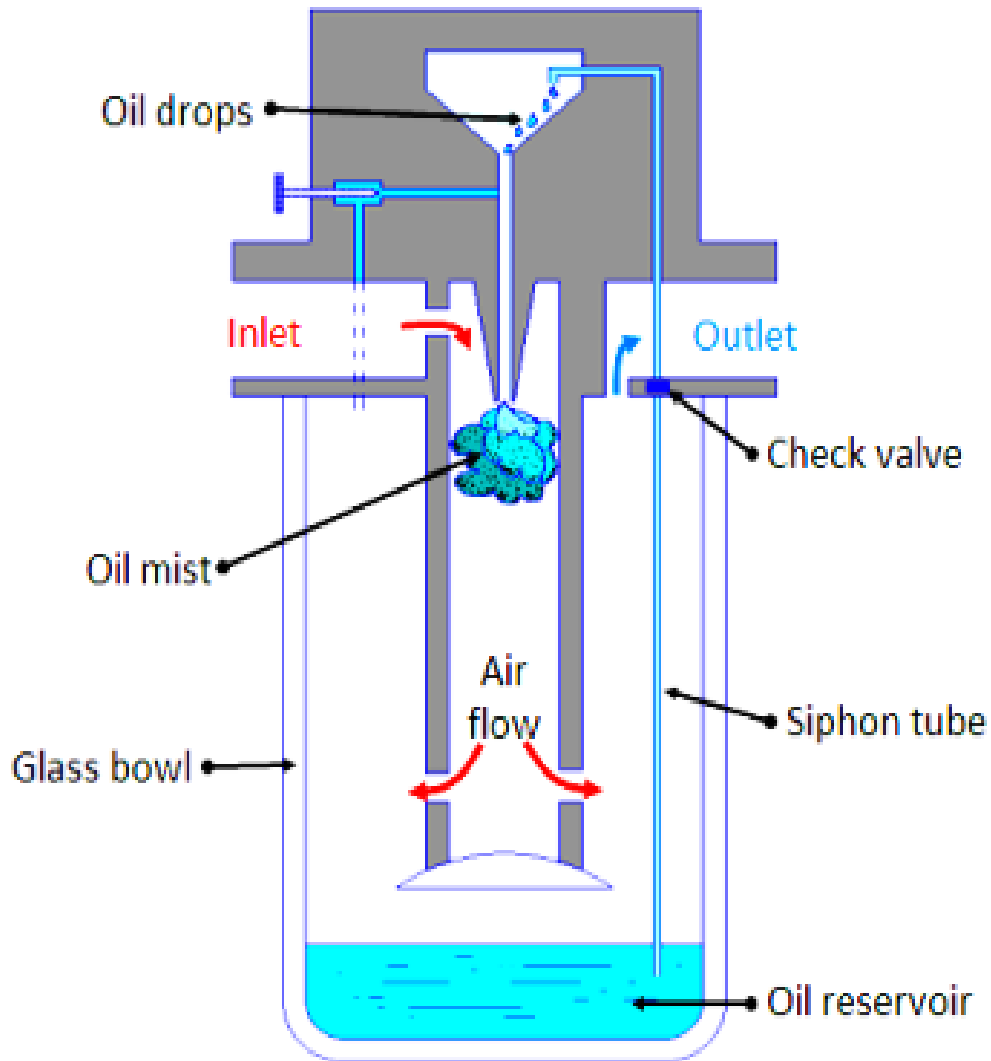

The compressed air is first filtered and then passed through a lubricator in order to form a mist of oil and air to provide lubrication to the mating components. The compressed air from the dryer enters in the lubricator. Its velocity increases due to a pressure differential between the upper and lower chamber (oil reservoir). Due to the low pressure in the upper chamber the oil is pushed into the upper chamber from the oil reservoir through a siphon tube with check valve. The main function of the valve is to control the amount of oil passing through it. The oil drops inside the throttled zone where the velocity of air is much higher and this high velocity air breaks the oil drops into tiny particles. Thus a mist of air and oil is generated. The pressure differential across chambers is adjusted by a needle valve. It is difficult to hold an oil mixed air in the air receiver as oil may settle down. Thus air is lubricated during secondary air treatment process. Low viscosity oil forms better mist than high viscosity oil and hence ensures that oil is always present in the air.

Pressure Regulation

In pneumatic systems, during high velocity compressed air flow, there is flow-dependent pressure drop between the receiver and load (application). Therefore the pressure in the receiver is always kept higher than the system pressure. At the application site, the pressure is regulated to keep it constant. There are three ways to control the local pressure, these are shown in Figure.

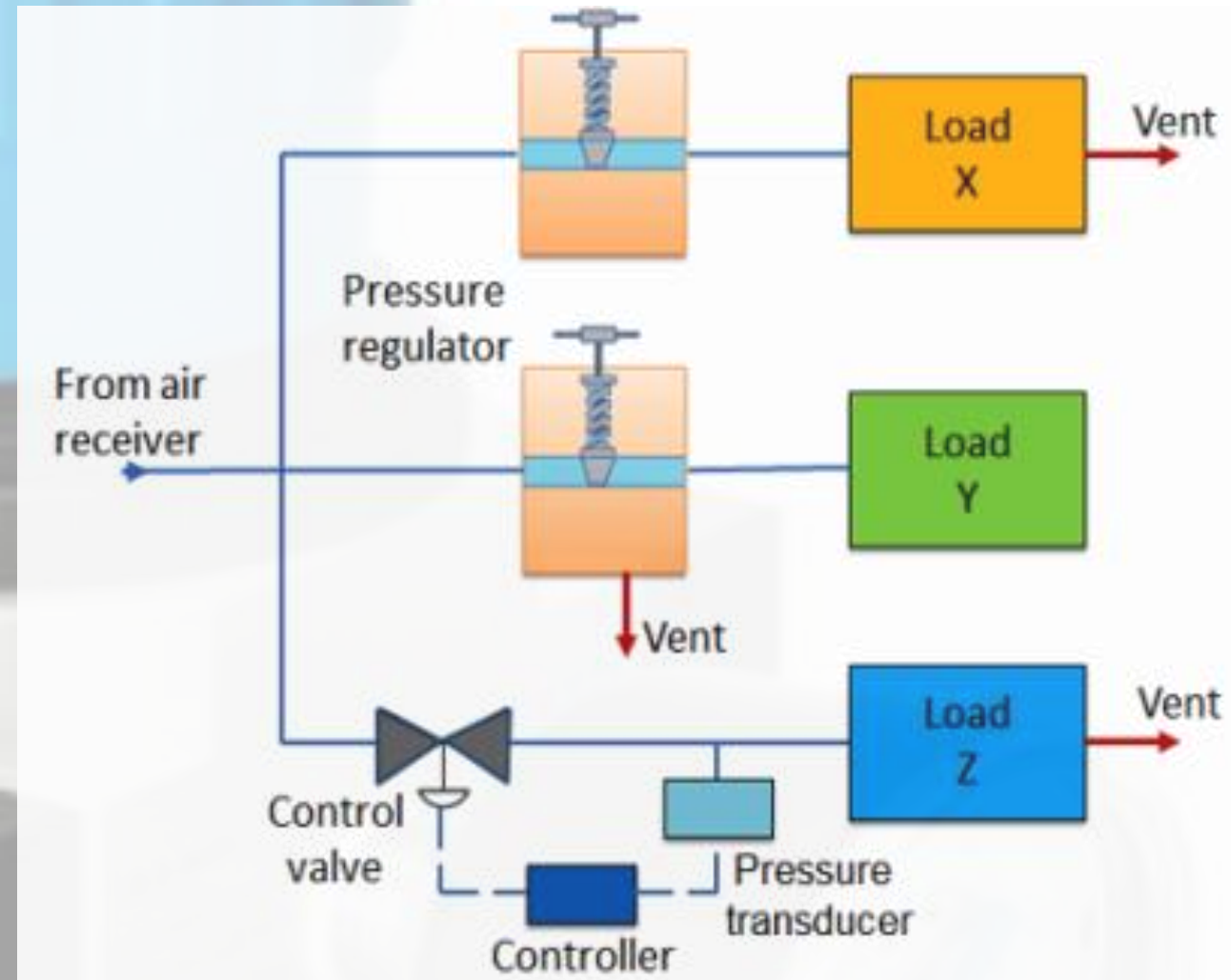

- **In the first method, load X vents the air into atmosphere continuously. The pressure regulator restricts the air flow to the load, thus controlling the air pressure. In this type of pressure regulation, some minimum flow is required to operate the regulator. If the load is a dead end type which draws no air, the pressure in the receiver will rise to the manifold pressure. These type of regulators are called as ‘non-relieving regulators’, since the air must pass through the load.**
- **In the second type, load Y is a dead end load. However the regulator vents the air into atmosphere to reduce the pressure. This type of regulator is called as ‘relieving regulator’.**
- **The third type of regulator has a very large load Z. Therefore its requirement of air volume is very high and can’t be fulfilled by using a simple regulator. In such cases, a control loop comprising of pressure transducer, controller and vent valve is used. Due to large load the system pressure may rise above its critical value. It is detected by a transducer. Then the signal will be processed by the controller which will direct the valve to be opened to vent out the air. This technique can be also be used when it is difficult to mount the pressure regulating valve close to the point where pressure regulation is needed.**

Relief Valve

Relief valve is the simplest type of pressure regulating device. It is used as a backup device if the main pressure control fails. It consists of ball type valve held on to the valve seat by a spring in tension. The spring tension can be adjusted by using the adjusting cap. When the air pressure exceeds the spring tension pressure the ball is displaced from its seat, thus releasing the air and reducing the pressure. A relief is specified by its span of pressure between the cracking and full flow, pressure range and flow rate. Once the valve opens (cracking pressure), flow rate depends on the excess pressure. Once the pressure falls below the cracking pressure, the valve seals itself.

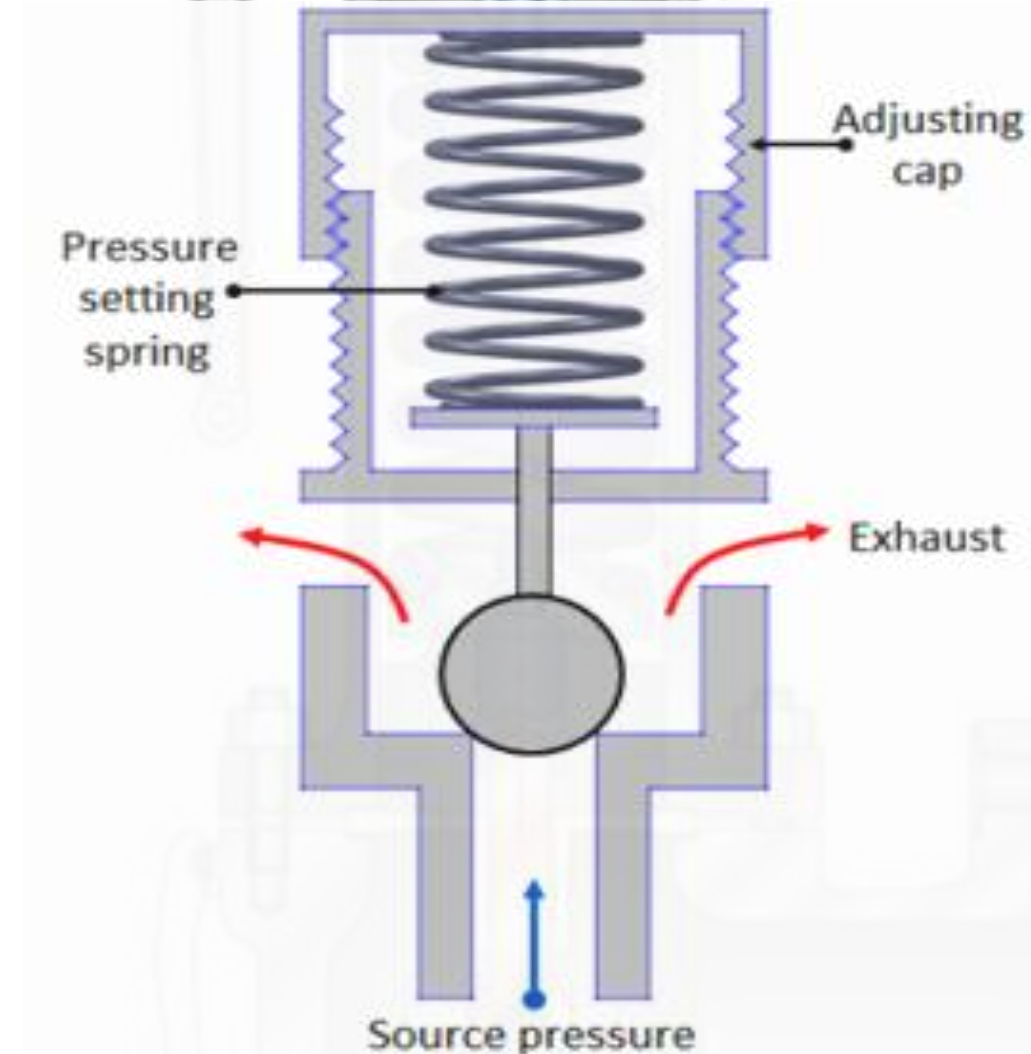

Non-Relieving Pressure Regulator

In a non-relieving pressure regulator the outlet pressure is sensed by a diaphragm which is preloaded by a pressure setting spring. If outlet pressure is too low, the spring forces the diaphragm and poppet to move down thus opening the valve to admit more air and raise outlet pressure. If the outlet pressure is too high the air pressure forces the diaphragm up hence reduces the air flow and causing a reduction in air pressure. The air vents away through the load. At steady state condition the valve will balance the force on the diaphragm from the outlet pressure with the preset force on the spring.

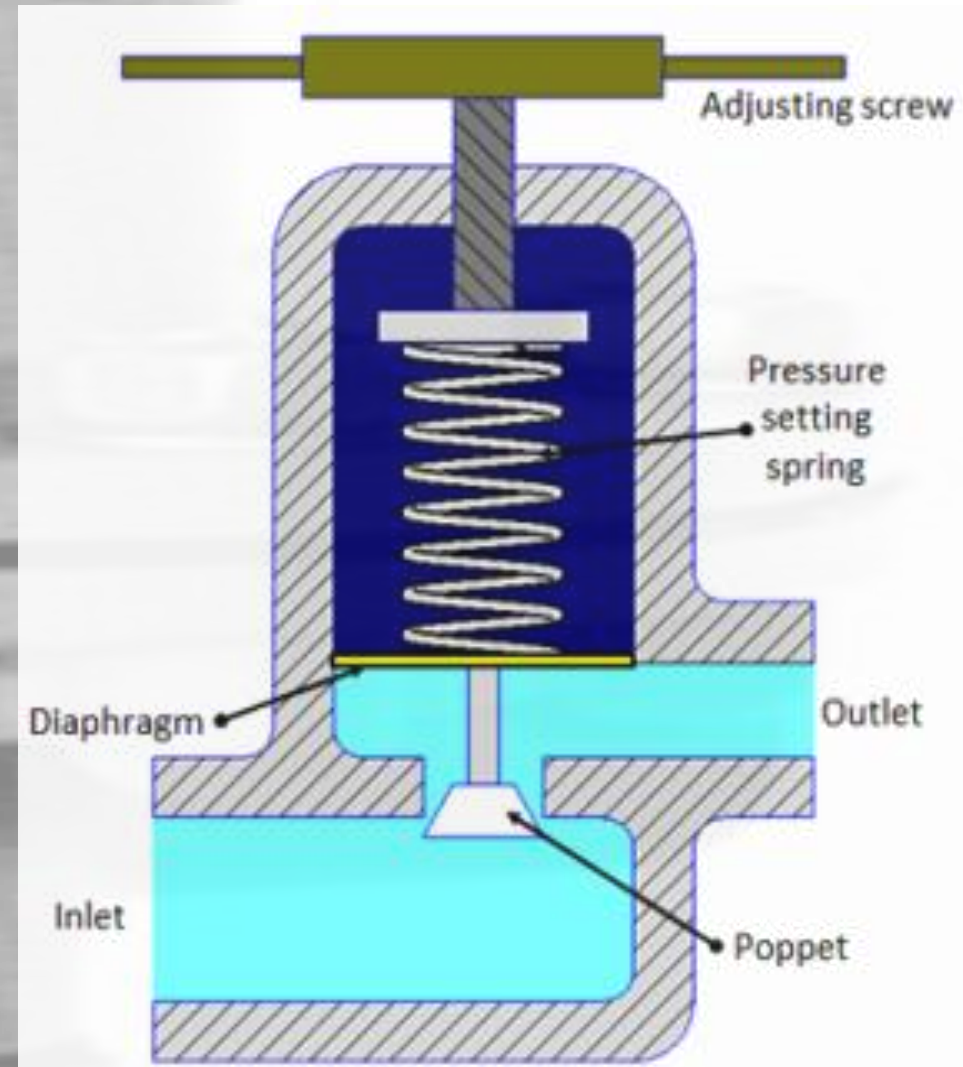

Service Units

- During the preparation of compressed air, various processes such as filtration, regulation and lubrication are carried out by individual components. The individual components are: separator/filter, pressure regulator and lubricator.
- Preparatory functions can be combined into one unit which is called as 'service unit'. Figure shows symbolic representation of various processes involved in air preparation and the service unit.

