



BASIC HYDRAULICS AND PNEUMATICS



Module 1: Introduction to Hydraulics

Module 1: Introduction to Hydraulics

▪ **Module Objectives**

After the completion of this module, the student will be able to:

- Identify the common uses of hydraulic systems.
- Determine that liquids are incompressible.
- Identify the fundamental parts of a hydraulic system.
- Observe how hydraulic components can be connected together to construct a hydraulic circuit.
- Identify the main components of the hydraulic work station TP 501.
- Explain the main parts of the hydraulic power pack.
- Explain the importance of using standard hydraulic symbols.
- Identify the basic hydraulic laws.
- Calculate the piston area, force, and pressure.
- Explain Pascal's law and apply it on different examples.
- Differentiate between the flow rate and flow velocity.
- Demonstrate the continuity equation.
- Calculate the area, velocity, and flow rate at different sections of a pipe.
- Describe how to read a pressure gauge in the US and SI units.
- Set the pressure gauge of the hydraulic power pack to a certain pressure.

Module 1: Introduction to Hydraulics

All machines require some type of power source and a way of transmitting this power to the point of operation.

The three methods of transmitting power are:

- Mechanical
 - Electrical
 - Fluid
- In this course we are going to deal with the third type of power transmission which is the **Fluid Power**

Module 1: Introduction to Hydraulics

- **Fluid power** is the method of using pressurized fluid to transmit energy.
- **Liquid** or **Gas** is referred to as a **fluid**. Accordingly, there are two branches of fluid power; **Pneumatics**, and **Hydraulics**.
- **Hydraulic systems** use **liquid** to transfer force from one point to another.
- **Pneumatic systems** use **air** to transfer force from one point to another. Air is

Module 1: Introduction to Hydraulics

- **Air is Compressible:**

(This describes whether it is possible to force an object into a smaller space than it normally occupies. For example, a sponge is compressible because it can be squeezed into a smaller size).

- **liquid is Incompressible:**

(The opposite to compressible. When a "squeezing" force is applied to an object, it does not change to a smaller size. Liquid, for example hydraulic fluid, possesses this physical property).

Module 1: Introduction to Hydraulics

- Hydraulic systems are commonly used where mechanisms require **large forces and precise control**.
- Examples include **vehicle power steering and brakes, hydraulic jacks** and **heavy earth moving machines**.



2. Uses of hydraulics

- Hydraulics plays an important role in many industries; there are a lot of **hydraulic applications** in manufacturing, transportation, and construction sectors.
- Hydraulics systems are used where large, precise forces are required.

2.1 Common examples of hydraulic systems include:

2.1.1 Vehicle brake hydraulic systems

The function of a vehicle braking system is to stop or slow down a moving vehicle. When the brake pedal is pressed as illustrated in Fig. 1.1, the hydraulic pressure is transmitted to the piston in the brake caliper of the brakes. The pressure forces the brake pads against the brake rotor, which is rotating with the wheel. The friction between the brake pad and the rotor causes the wheel to slow down and then stop.

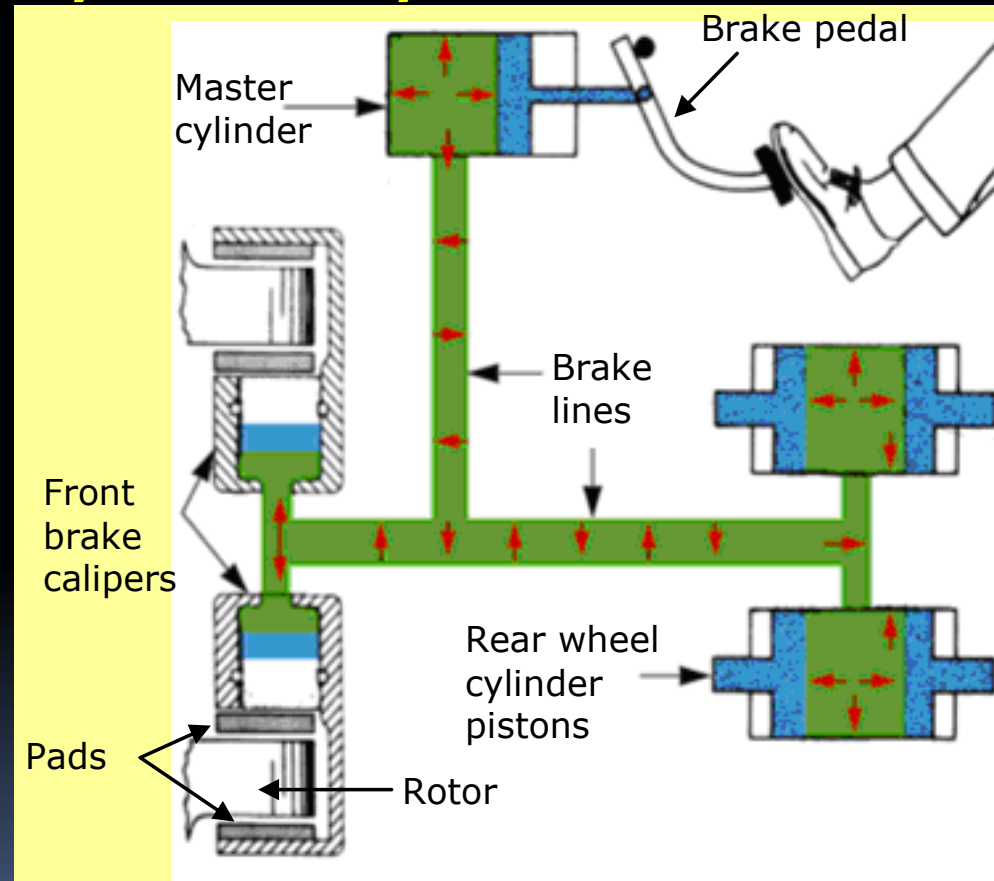

Tip: Watch the hydraulic brake system video.

Fig.1.1: A schematic diagram of the vehicle's hydraulic brake system.

2.1 Common examples of hydraulic systems include:

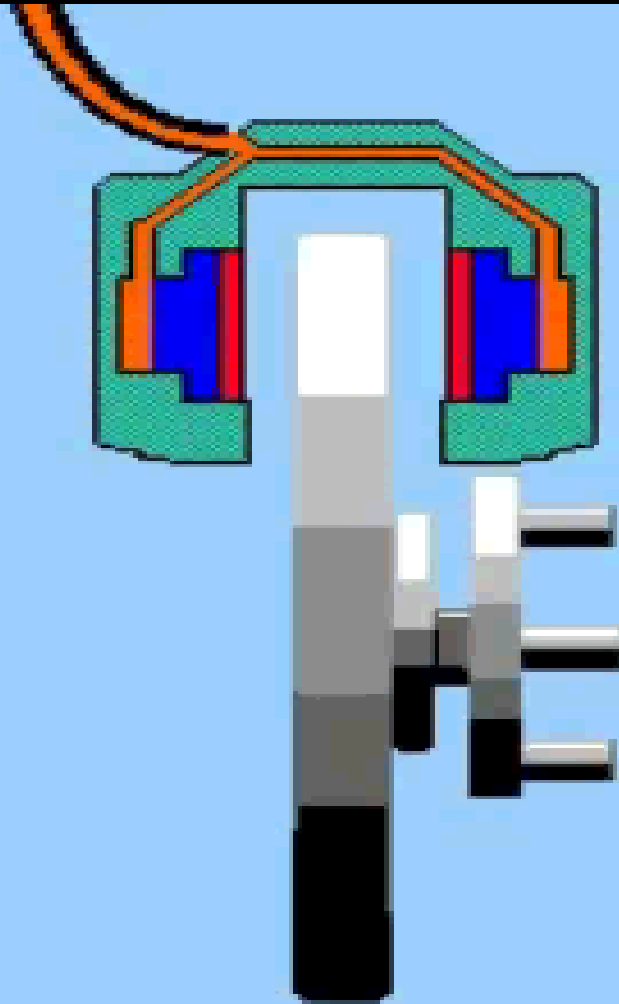

2.1 Common examples of hydraulic systems include:

2.1.2 Vehicle power steering

- The vehicle power steering system uses hydraulic oil, the **hydraulic pump** supplies the oil through the **control valves** to the power cylinder as shown in Fig. 1.2. **The major advantage of using this system is to turn the vehicle's wheels with less effort.**

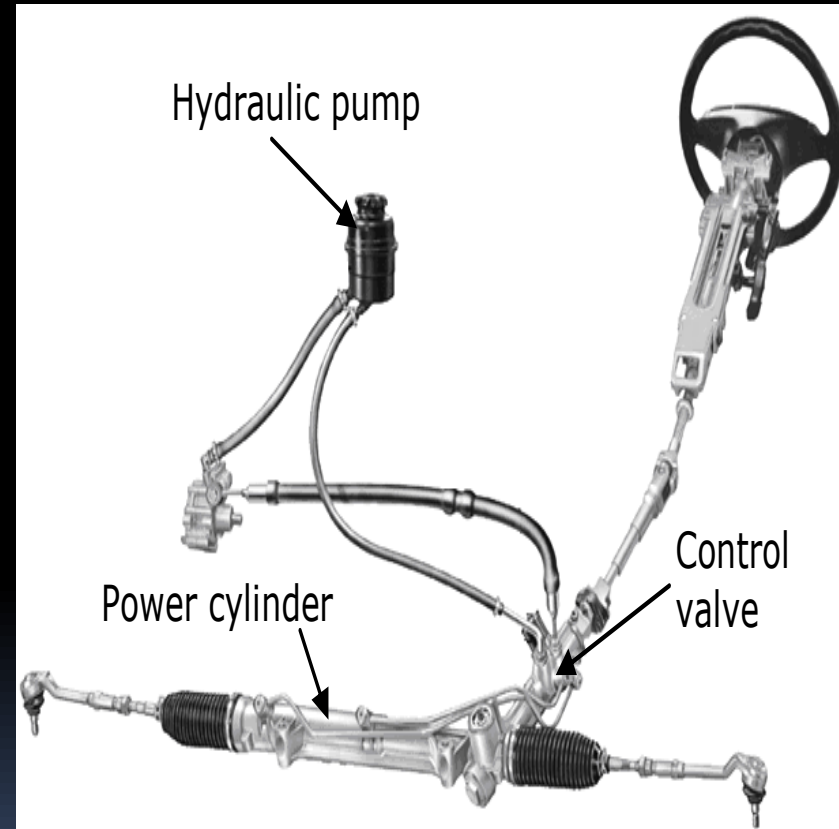

Fig.1.2:Vehicle hydraulic power steering system

2.1 Common examples of hydraulic systems include:

2.1.3 Hydraulic jack

- In a hydraulic jack, a small piston (pumping piston) transmits pressure through the oil to a large piston (power piston) through a check valve, resulting in the weight being lifted as shown in Fig.1.3.

- **Tip: Watch the hydraulic jack video.**



(a) Hydraulic jack

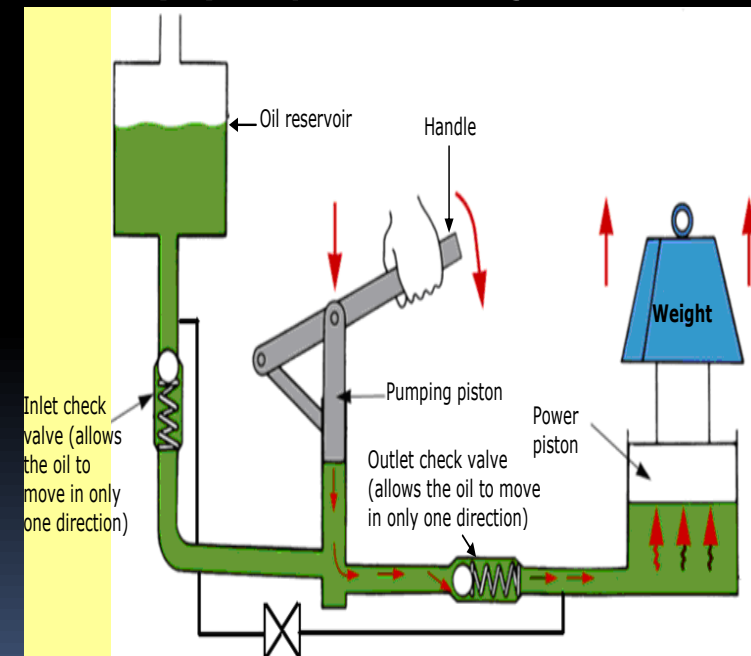

(b) Hydraulic jack schematic diagram



Tip: Watch the hydraulic jack video.

- <https://www.youtube.com/watch?v=iXXt2oGXvmo>

2.1 Common examples of hydraulic systems include:

2.1.4 Aircraft hydraulic systems

- All modern aircraft contain hydraulic systems to operate mechanisms, such as:
- Flaps (Fig. 1.4a)
- Landing gear (Fig. 1.4a)
- The hydraulic pump that is coupled to the engine provides hydraulic power as illustrated by Fig. 1.4b.
- Power is also distributed to systems through the aircraft by transmission lines.
- Hydraulic power is converted to mechanical power by means of an actuating cylinder or hydraulic motor.

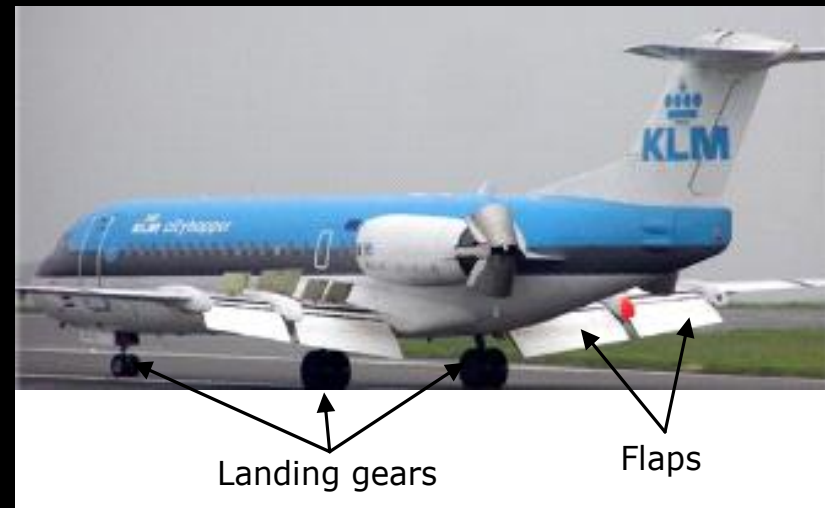

(a) Landing gears and flaps

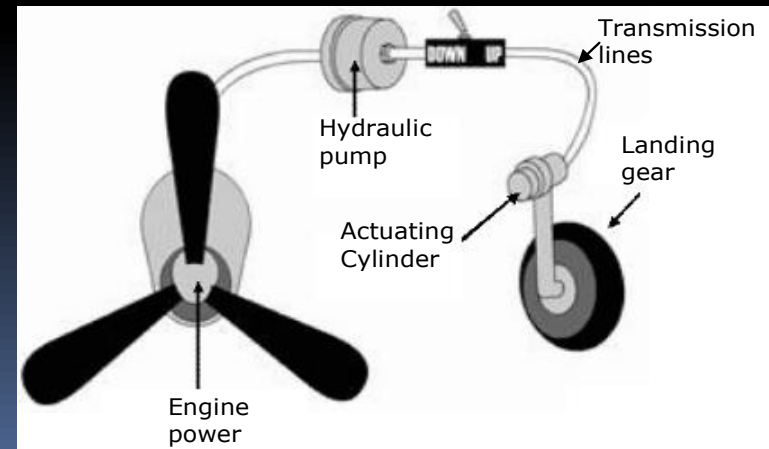

(b) Landing gear schematic diagram

3 Hydraulic system components

- All industrial hydraulic systems consist of the following basic components
- **Power input device:**

The pump and motor together are called the power input device; the pump provides power to the hydraulic system by pumping oil from the reservoir/tank. The pump's shaft is rotated by an external force which is most often an electric motor as illustrated in Fig 1.5.

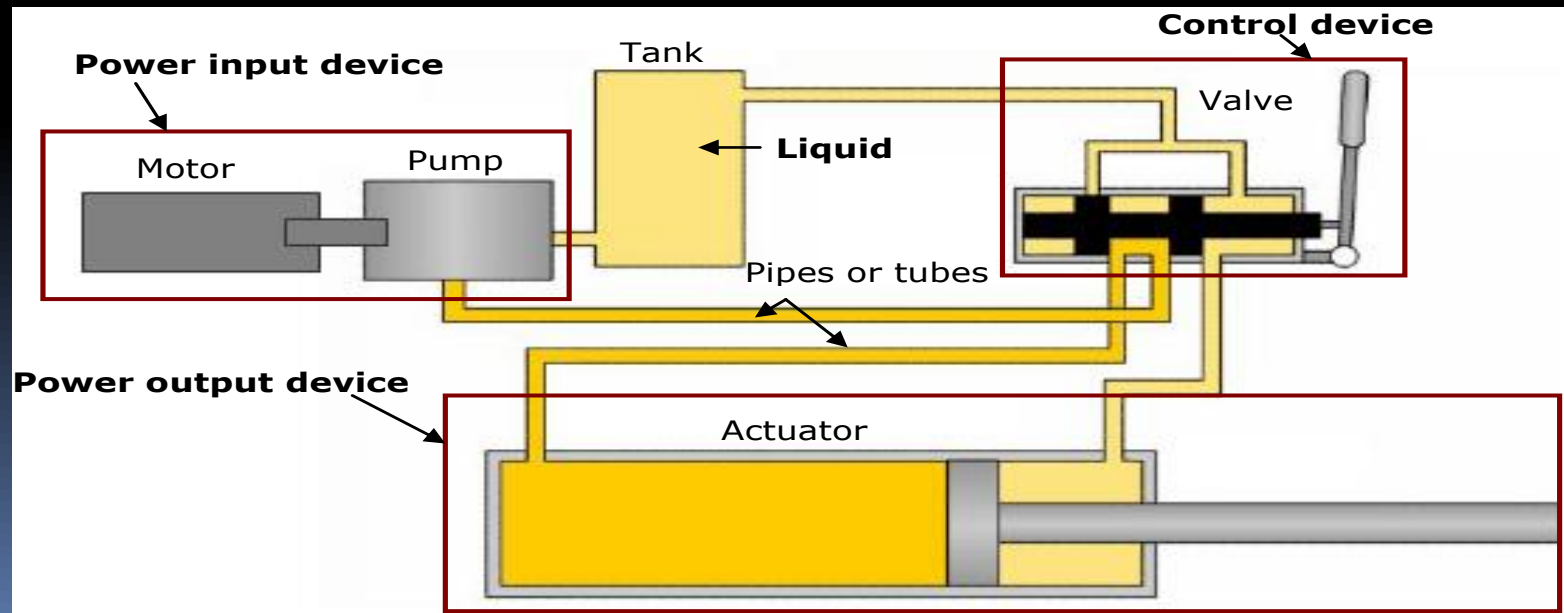

3 Hydraulic system components

- **Control device:** Valves control the direction, pressure, and flow of the hydraulic fluid from the pump to the actuator/cylinder.
- **Power output device:** The hydraulic power is converted to mechanical power inside the power output device. The output device can be either a cylinder which produces linear motion or a motor which produces rotary motion.
- **Liquid:** the liquid is the medium used in hydraulic systems to transmit power. The liquid is typically oil, and it is stored in a tank or reservoir.
- **Conductors:** The conductors are the pipes or hoses needed to transmit the oil between the hydraulic components.

3.1 Hydraulic power pack

- The hydraulic power pack combines the pump, the motor, and the tank. The hydraulic power pack unit provides the energy required for the hydraulic system. The parts of the hydraulic power pack unit are shown in Fig. 1.6.

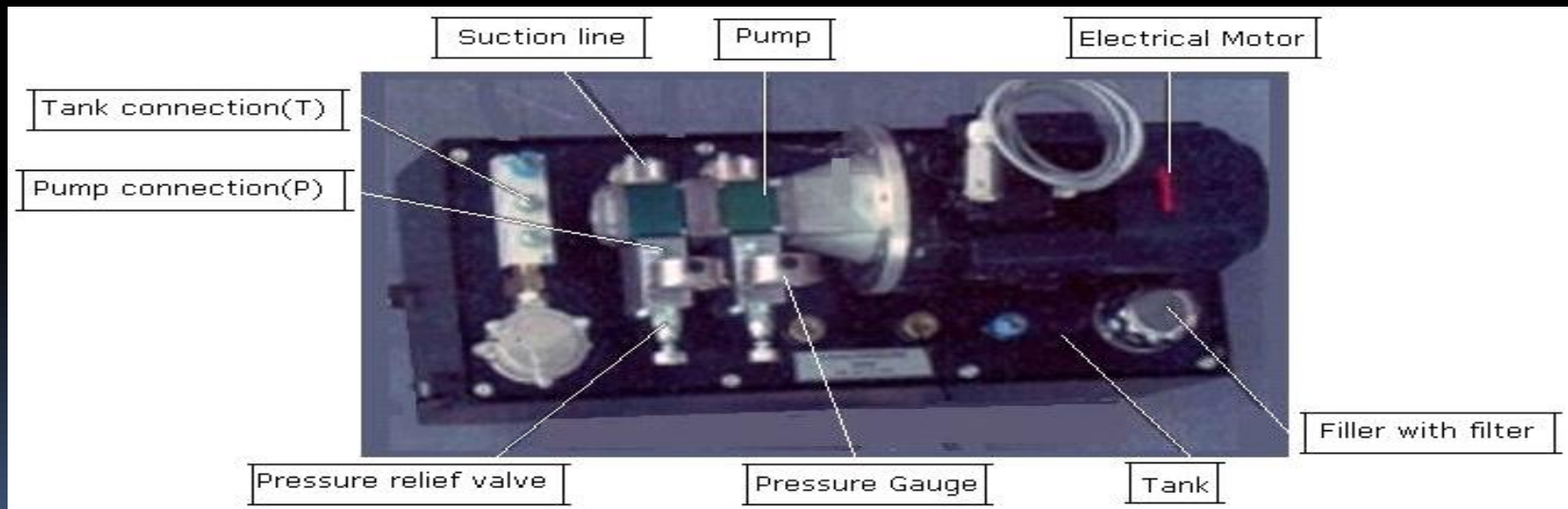

.1.6: The main parts of the hydraulic power pack

3.3 Hydraulic symbols

- The way hydraulic components direct and control liquid around a circuit can be complex.
- This would cause difficulty for one engineer explaining to another engineer how the circuit works.
- A common form of representing components and circuits is used to more easily explain what is happening.
- This form of representation uses common symbols to represent components and the ways in which they are connected to form circuits. Fig. 1.7 shows some of the components' symbols used in hydraulics.
- The symbols don't show the component construction, or size, however, it is a standard form that is used by all engineers to represent that specific component.



(a) Electric motor



(b) Hydraulic pump

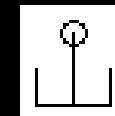

(c) Tank or reservoir

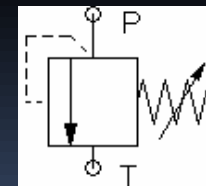

(d) Pressure relief valve

Fig.1.7: (a) Electric motor. (b) Hydraulic pump. (c) Tank or reservoir. (d) Pressure relief valve.

Power Pack Symbols

- The simplified and detailed symbols of the hydraulic power pack are shown in Fig. 1.8.

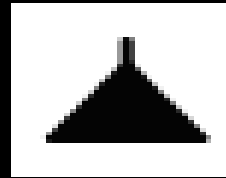

(a) Simplified

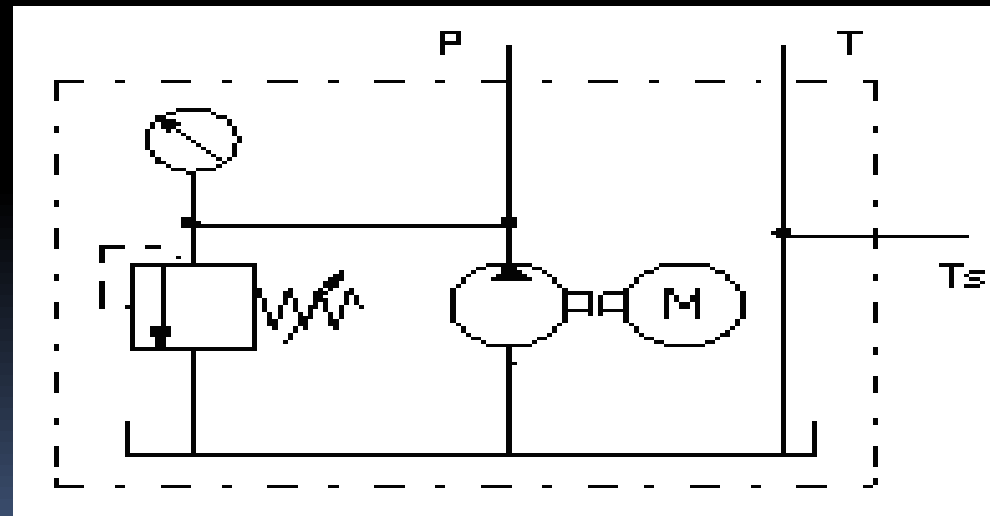

(b) Detailed

Fig.1.8: (a) Simplified symbol of the hydraulic power pack.

(b) Detailed symbol of the hydraulic power pack.

4- Fundamental laws of Hydraulics

- All hydraulic systems operate following a defined relationship between area, force and pressure.
- Laws have been established to explain the behavior of hydraulic systems.
- Hydraulic systems use the ability of a fluid to distribute an applied force to a desired location.

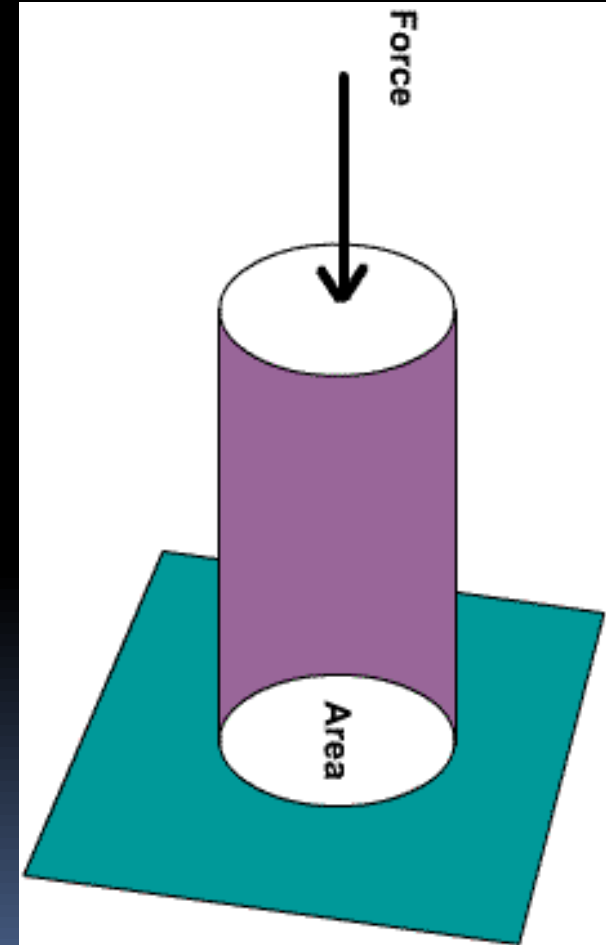

4- Fundamental laws of Hydraulics

4.1 Pressure

- When a **force (F)** is applied on an **area (A)** of an enclosed liquid, a **pressure (P)** is produced as shown in Fig.
- **Pressure** is the distribution of a given force over a certain area.
- Pressure can be quoted in **bar**, **pounds per square inch (PSI)** or **Pascal (Pa)** .

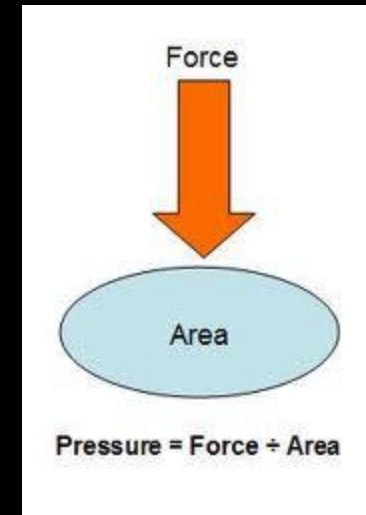

$$P = \frac{F}{A}$$

4.1 Pressure

$$P = \frac{F}{A}$$

Where

Force is in newtons (N) and

Area is in square meters (m²).

1 Pascal (Pa) = 1 N/m².

1 bar = 100,000 Pa = 10⁵ Pa.

10 bar = 1 MPa (mega Pascals)

4.1 Pressure

- If the pressure is calculated using a force in Newton, and area in square millimeters, the pressure in bar can be calculated.

Example 1-1.

A cylinder is supplied with 100 bar pressure; its effective piston surface is equal to 700 mm². Find the maximum force which can be attained.

- $P = 100 \text{ bar} = 100 \times 1000000 \text{ N/m}^2$.
- $A = 700 / 1000000 = 0.0007 \text{ m}^2$.
- $F = P \cdot A = 100 \times 1000000 \times 0.0007 = 7,000 \text{ N}$



4.2 Pascal's Law

- **Pascal's law** states that:
"The pressure in a confined fluid is transmitted equally to the whole surface of its container"
- When **force F** is exerted on **area A** on an enclosed liquid, **pressure P** is produced. **The same pressure applies at every point of the closed system** as shown in Fig. 1.10a.

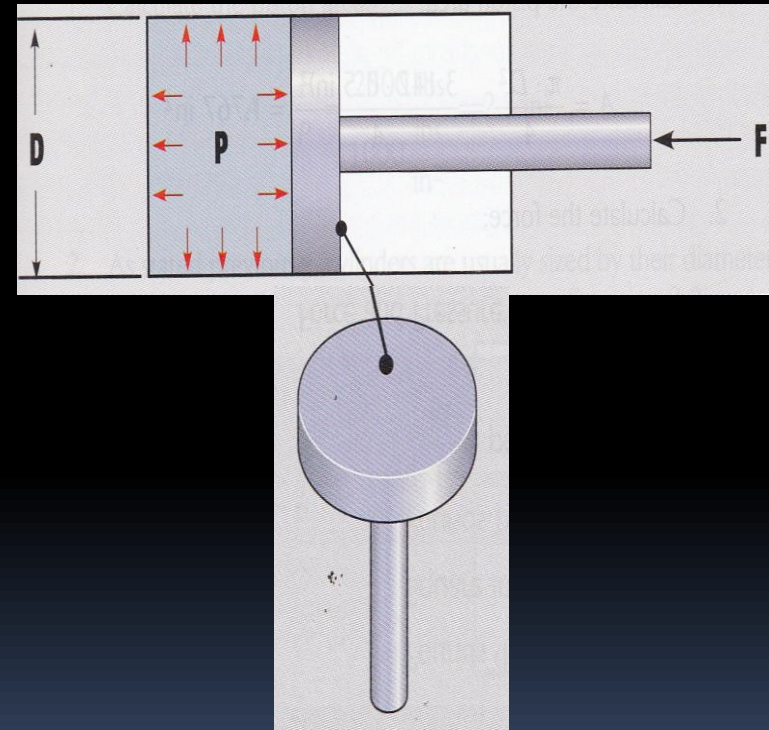
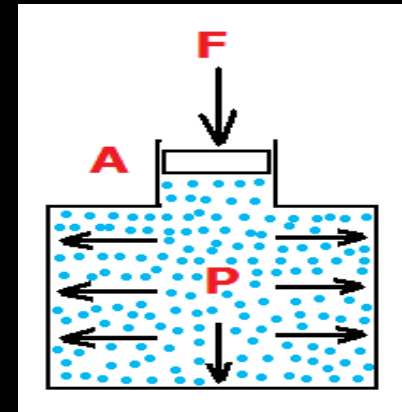
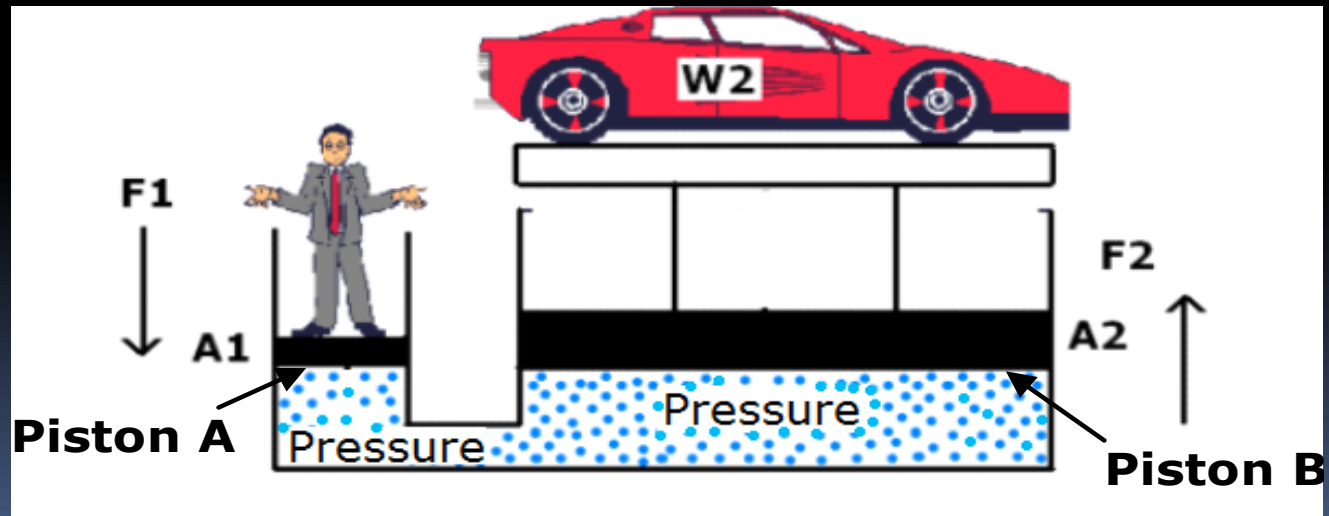

Fig.1.10: (a) Pascal's law.

4.2 Pascal's Law

- Fig.1.10b shows that, if a downward **force** is applied **to piston A**, it will be transmitted through the system **to piston B**.
- According to **Pascal's law**, the pressure at **piston A (P_1)** equals the pressure at **piston B (P_2)**



$$P_1 = P_2$$

Fig.1.10: (b) Power transmission

4.2 Pascal's Law

$$P_1 = P_2$$

Fluid pressure is measured in terms of the force exerted per unit area.

$$P = \frac{F}{A}$$

$$P_1 = \frac{F_1}{A_1}$$

$$P_2 = \frac{F_2}{A_2}$$

$$\frac{F_1}{A_1} = \frac{F_2}{A_2}$$

The values F_1 , A_2 can be calculated using the following formula:

$$F_1 = \frac{A_1 \times F_2}{A_2}$$

, and

$$A_2 = \frac{A_1 \times F_2}{F_1}$$

4.2 Pascal's Law

- **Example 1-2.**
- In Fig.11, find the weight of the car in N, if the area of piston **A** is 0.0006m^2 , the area of piston **B** is 0.0105 m^2 , and the **force** applied on piston A is 500 N .

- **Solution:**

$$P_1 = P_2$$

$$\frac{F_1}{A_1} = \frac{F_2}{A_2}$$

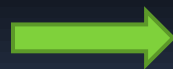

$$F_2 = \frac{F_1 \times A_2}{A_1}$$



$$F_2 = \frac{500 \times 0.0105}{0.0006}$$



$$F_2 = 8750\text{ N} = 8.75\text{ kN}$$

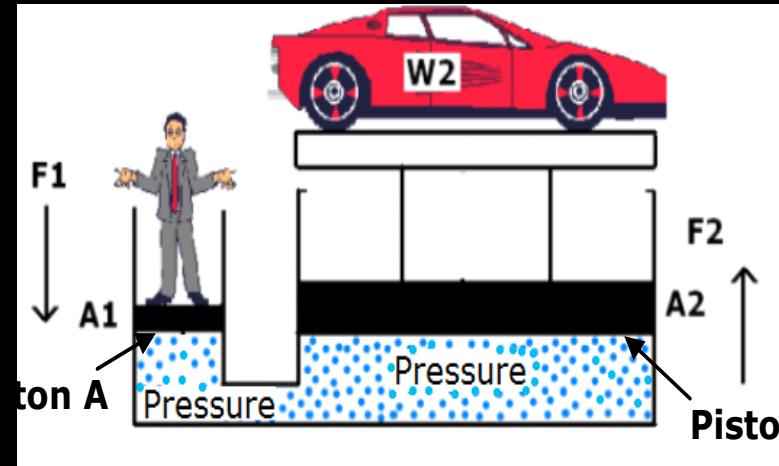

4.2 Pascal's Law

- **Example 1-3.**

In Fig 1.11, if the weight of the car is 10,000 N, the diameter of piston A is 0.01 m, and the force applied on piston A is 250 N. Calculate the area of piston B.

- **Solution:**

1. Calculate the area of piston A, the piston shape is circular as shown in Fig. 1.10a, accordingly the area will be calculated using the following formula.

$$A_1 = \pi \frac{D^2}{4} = 3.14 \times \frac{(0.01)^2}{4} = 0.0000785 \text{ m}^2$$

$$F_1 = 250 \text{ N}$$

$$F_2 = 10,000 \text{ N}$$

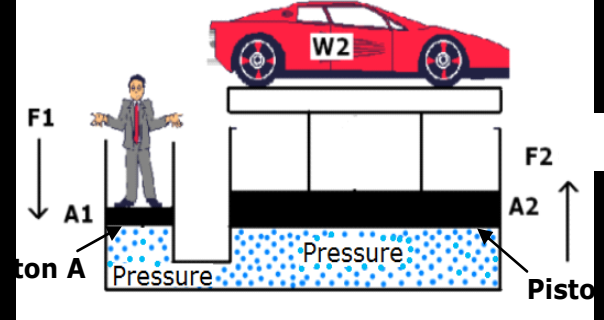

4.2 Pascal's Law

- 2. Apply Pascal's law

$$P_1 = P_2$$

$$\frac{F_1}{A_1} = \frac{F_2}{A_2}$$

- 3. Use Pascal's law to calculate the area of piston B

$$A_2 = \frac{A_1 \times F_2}{F_1}$$

$$A_2 = \pi \times \frac{(D_2)^2}{4} = 0.003140\text{m}^2$$

$$A_2 = \frac{0.0000785 \times 10,000}{250} = 0.00314\text{m}^2$$

4.3 Liquid flow

4.3.1 Flow rate versus flow velocity

The flow rate is the volume of fluid that moves through the system in a given period of time.

Flow rates determine the speed at which the output device (e.g., a cylinder) will operate.

The flow velocity of a fluid is the distance the fluid travels in a given period of time.

These two quantities are often confused, so care should be taken to note the distinction. The following equation relates the flow rate and flow velocity of a liquid to the size (area) of the conductors (pipe, tube or hose) through which it flows.

$$Q = V \times A$$

Where:

Q= flow rate (m^3/s)

V= flow velocity (m/s)

A= area (m^2)

4.3 Liquid flow

This is shown graphically in Fig. 1.11. Arrows are used to represent the fluid flow. It is important to note that the area of the pipe or tube being used.



Fig.1.11: Flow velocity and flow rate

4.3 Liquid flow

- **Example 1-4.**

A fluid flows at a velocity of 2 m/s through a pipe with a diameter of 0.2 m. Determine the flow rate.

Solution:

1. Calculate the pipe area

$$A = \pi \frac{D^2}{4} = 3.14 \times \frac{(0.2)^2}{4} = 0.0314 \text{ m}^2$$

2. Calculate the flow rate

$$Q = V \times A$$

$$Q = 2 \times 0.0314 = 0.0628 \frac{\text{m}^3}{\text{Sec}}$$

4.3.2 The continuity equation

Hydraulic systems commonly have a pump that produces a constant flow rate. If we assume that the fluid is incompressible (oil), this situation is referred to as steady flow. This simply means that whatever volume of fluid flows through one section of the system must also flow through any other section. Fig. 1.12 shows a system where flow is constant and the diameter varies

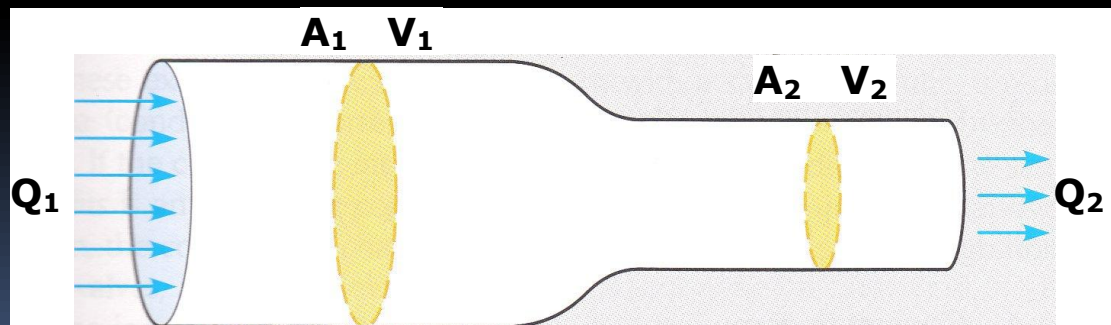

Fig.1.12: Continuity of flow.

4.3.2 The continuity equation

The following equation applies in this system:

$$Q_1 = Q_2$$

Therefore,

$$V_1 \times A_1 = V_2 \times A_2$$

The following example illustrates the significance of the continuity equation shown above.

4.3.2 The continuity equation

- **Example 1-5.**
- A fluid flows at a velocity of 0.2 m/s at point 1 in the system shown in Fig. 1.12. The diameter at point 1 is 50mm and the diameter at point 2 is 30 mm. Determine the flow velocity at point 2. Also determine the flow rate in m/s.
- **1. Calculate the areas**

$$A_1 = \pi \times \frac{D_1^2}{4} = 3.14 * \frac{(50 \times 10^{-3})^2}{4} = 1.963 \times 10^{-3} m^2$$

$$A_2 = \pi \times \frac{D_2^2}{4} = 3.14 * \frac{(30 \times 10^{-3})^2}{4} = 7.068 \times 10^{-4} m^2$$

4.3.2 The continuity equation

2. Calculate the velocity at point 2

$$Q_1 = Q_2$$

Therefore,

$$V_1 \times A_1 = V_2 \times A_2$$

$$V_2 = V_1 \times \frac{A_1}{A_2} = 0.2 \times \frac{1.963 \times 10^{-3}}{7.068 \times 10^{-4}} = 0.55 \text{ m/s}$$

3. Calculate the flow rate in m³/s

$$Q_1 = V_1 \times A_1 = 0.2 \times 1.963 \times 10^{-3} = 3.926 \times 10^{-4} \text{ m}^3/\text{s}$$

4.3.2 The continuity equation

The example shows that in a system with a steady flow rate, a reduction in area (pipe size) corresponds to an increase in flow velocity by the same factor. If the pipe diameter increases, the flow velocity is reduced by the same factor. This is an important concept to understand because in an actual hydraulic system, the pipe size changes repeatedly as the fluid flows through hoses, fittings, valves, and other devices.

5 Reading the pressure gauge

- The pressure gauge indicates the amount of pressure in a system. Technicians read these gauges to determine if a machine is operating properly.
- Most pressure gauges have a face plate that is graduated either in US units (psi) or SI units (Pascal or bar) note that;
1 bar=0.1 mega pascals as explained

5 Reading the pressure gauge

- A pointer rotates on the graduated scale as the pressure changes to indicate the pressure in the system. The pressure gauge used in the hydraulic power pack is shown in Fig. 1.13. The outer black scale indicates pressure units of bar, and the inner red scale indicates pressure units in psi

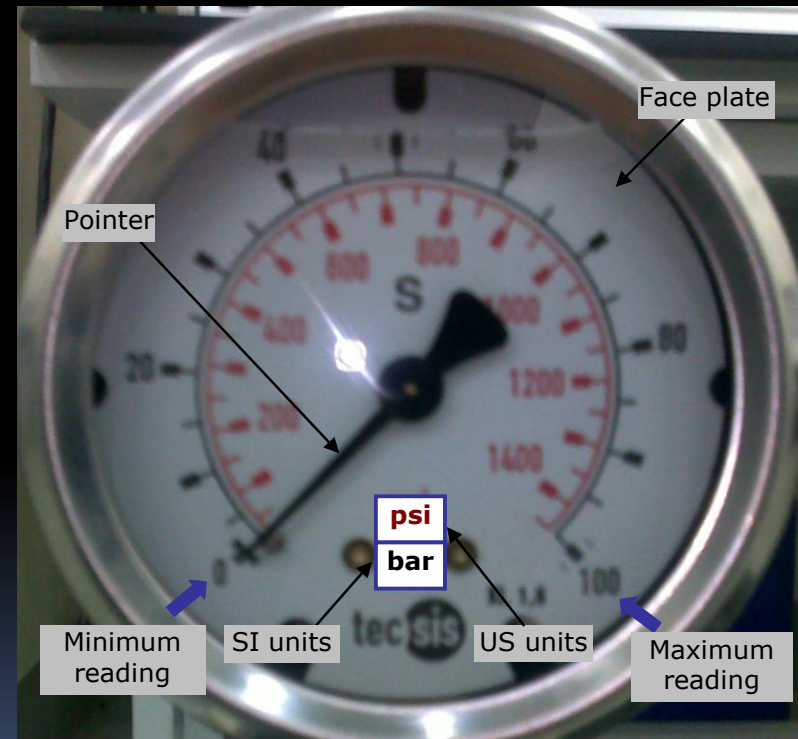

Fig. 1.13: A pressure gauge.

5 Reading the pressure gauge

- Each scale is graduated with a series of numbers ranging from 0 to a maximum number. In case of the gauge shown, it is graduated from 0 to a maximum reading of 100 bar or a maximum reading of 1450 psi. The maximum reading is always called the range of the gauge.
- To read the pressure gauge, you only need to read the inner red scale or the outer red scale to which the pointer points. If the pointer points to a position between the two numbers, you read the gauge to the closest graduation.
- In the bar scale there are 4 graduations between 0 and 20; this means the value of each graduation is $20/4=5$ bar. In the psi scale there are 4 graduations between 0 and 200; this means the value of each graduation is $200/4=50$ psi.

5.1 Activity 2: Setting the hydraulic pressure to 30 bar.

Procedures:

- 1- Switch on the electrical power supply first and then the hydraulic power pack.
- 2- Use the pressure relief valve to set the pressure to 30 bars.
- 3- While you are adjusting the pressure observe the pressure gauge.
- 4- When the pressure gauge indicates 30 bar, switch off the hydraulic power pack first, and then the electrical power supply

For more information, refer to the movie section



Fig. 1.13: The hydraulic power pack.